

**TOSHIBA**

**G500** 高機能携帯

User guide



# Table of contents

## **Network Services 6**

### **Toshiba Corporation 7**

EU Warranty 10

### **Licenses 11**

### **Declaration of conformity 13**

### **Care and maintenance 14**

Care and maintenance 14

Restarting your Toshiba phone 15

Hard resetting your Toshiba phone 15

### **Safety instructions 16**

Wireless LAN security 16

Bluetooth security 16

FCC notice 16

Information to user 17

## **Getting Started 18**

Unpacking 18

Phone layout and functions 19

Charging the battery 28

Switching the power on and off 29

Synchronizing 29

## **Call Functions 32**

Making a call 32

Receiving a call 34

In-call options 35

Special dialling requirements 36

Video telephony 37

Call history 38

## **Messaging 40**

Text (SMS) messaging 40

Email 42

MMS messaging 48

Pocket MSN 52



# Table of contents

## Text Input 54

Input methods 54

Method indicators 54

Multi-press mode 54

XT9 mode 55

Numeric mode 55

## Settings 56

Customizing your Home screen 56

Sounds 56

Profiles 57

Clock & alarm settings 58

Owner information 58

Changing accessibility settings 58

Changing regional settings 59

Changing power management settings  
59

Security settings 59

Phone settings 62

Removing Programs 64

Error Reporting 64

Video call settings 65

SIMLock settings 65

Viewing the About details 65

# Table of contents

## Connectivity 66

Automatic set up of your data connections 66

Manual set up of your data connections 66

Bluetooth 70

Beams 73

Checking for a Wireless LAN signal 74

Wireless Manager 74

USB to PC 76



# Table of contents

## **Applications & Multimedia 77**

Internet Explorer 77

Tasks 78

Windows Media 80

Calendar 84

Messaging 86

Contacts 86

ActiveSync 88

Call History 88

Settings 88

Games 89

Voice Notes 89

Pictures & Videos 89

Accessories 93

Internet Sharing 93

File Explorer 94

FingerLaunch 94

GoldKey 95

Java 95

Opera Browser 96

Picxel Viewer 97

Pocket MSN 97

SIM Manager 97

Speed Dial 98

Teleport 98

TIPtalk 100

Zoom 102

## **Other applications 104**

Battery information 104

PC requirements to run ActiveSync 4.2  
105

## **Specifications 106**

## **Troubleshooting 109**

# Table of contents

## Health and safety 110

General 110

Operating environment 111

Electronic devices 112

Battery safety 112

AC adapter and cable safety 113

Emergency calls 114

FCC RF exposure information 114

European RF Exposure Information 115

Purchase record 117

## Menu Tree 118

## Index 119



## Network Services

To use your Toshiba phone you must have service from a wireless service provider. Many of the features in your Toshiba phone depend on features in the wireless network to function. These Network Services may not be available on all networks or you may have to make specific arrangements with your service provider before you can utilise Network Services. Your service provider may need to give you additional instructions for their use and explain what charges will apply. Some networks may have limitations that affect how you can use Network Services. For instance, some networks may not support all language-dependent characters and services.

This phone is a 3GPP GSM Release 99 terminal supporting GPRS service, and is designed to support also Release 97 GPRS networks. However, there may be some compatibility issues when used in some Release 97 GPRS networks. For more information, contact your service provider.

The availability of particular products may vary by region. Please check with the dealer nearest to you.



# Toshiba Corporation

IMPORTANT NOTE: PLEASE READ BEFORE USING YOUR MOBILE PHONE BY ATTEMPTING TO USE ANY SOFTWARE ON THE SUPPLIED PHONE CONSTITUTES YOUR ACCEPTANCE OF THESE EULA TERMS. IF YOU REJECT OR DO NOT AGREE WITH ALL THE TERMS OF THIS EULA, PLEASE DO NOT ATTEMPT TO ACCESS OR USE THE SUPPLIED SOFTWARE.

## End User License Agreement

This End User License Agreement ("EULA") is a legal agreement between you (as the user) and TOSHIBA CORPORATION ("Toshiba") with regard to the copyrighted software installed in a Toshiba 3G mobile phone supplied to you (the "Phone").

Use or employment of any software installed in the Phone and related documentations (the "Software") will constitute your acceptance of these terms, unless separate terms are provided by the Software supplier on the Phone, in which case certain additional or different terms may apply. If you do not agree with the terms of this EULA, do not use or employ the Software.

1. **License Grant.** Toshiba grants to you a personal, non-transferable and non-exclusive right to use the Software as set out in this EULA. Modifying, adapting, translating, renting, copying, making available, transferring or assigning all or part of the Software, or any rights granted hereunder, to any other persons and removing any proprietary notices, labels or marks from the Software is strictly prohibited, except as expressly permitted in this EULA. Furthermore, you hereby agree not to create derivative works based on the Software.
2. **Copyright.** The Software is licensed, not sold. You acknowledge that no title to the intellectual property in the Software is or will be transferred to you. You further acknowledge that title and full ownership rights to the Software will remain the exclusive property of Toshiba, Toshiba's affiliates, and/or their suppliers, and you will not acquire any rights to the Software, except as expressly set out in this EULA. You may keep a backup copy of the Software only so far as necessary for its lawful use. All copies of the Software must contain the same proprietary notices as contained in the Software and are subject to the terms of this EULA. All rights not expressly granted under this EULA are reserved





# Toshiba Corporation

to Toshiba, Toshiba's affiliates and/or their suppliers.

- Reverse Engineering.** You agree that you will not attempt, and if you are a business organisation, you will use your best efforts to prevent your employees, workers and contractors from attempting to reverse engineer, decompile, modify, translate or disassemble the Software in whole or in part except to the extent that such actions cannot be excluded by mandatory applicable law and only if those actions are taken in accordance with such applicable law. Any failure to comply with the above or any other terms and conditions contained herein will result in the automatic termination of this license and the reversion of the rights granted hereunder to Toshiba.
- LIMITED WARRANTY.** Only during the warranty period for the Phone, Toshiba, Toshiba's affiliate, its suppliers or its authorized service company will repair or replace, at Toshiba's sole discretion, defective Software unless such defect results from acts or incidences beyond the reasonable control of Toshiba. EXCEPT AS PROVIDED IN THIS EULA: (A) TOSHIBA, TOSHIBA'S AFFILIATES, AND THEIR SUPPLIERS DISCLAIM ALL

WARRANTIES, CONDITIONS OR OTHER TERMS (WHETHER EXPRESS OR IMPLIED), INCLUDING BUT NOT LIMITED TO WARRANTIES, CONDITIONS AND TERMS OF SATISFACTORY QUALITY, MERCHANTABILITY, FITNESS FOR A PARTICULAR PURPOSE AND NON-INFRINGEMENT OF THIRD-PARTY RIGHTS; AND (B) THE ENTIRE RISK AS TO THE QUALITY AND PERFORMANCE OF THE SOFTWARE IS WITH YOU. YOU ACCEPT THAT SOFTWARE MAY NOT MEET YOUR REQUIREMENTS AND NO WARRANTY CAN BE GIVEN THAT OPERATION OF THE SOFTWARE WILL BE UNINTERRUPTED OR ERROR-FREE.

- LIMITATION OF LIABILITY.** TO THE FULLEST EXTENT LEGALLY PERMITTED, IN NO EVENT SHALL TOSHIBA, TOSHIBA'S AFFILIATES OR THEIR SUPPLIERS BE LIABLE TO YOU FOR ANY DAMAGES FOR (A) LOST BUSINESS OR REVENUE, BUSINESS INTERRUPTION, LOSS OF BUSINESS DATA; OR (B) CONSEQUENTIAL, SPECIAL, INCIDENTAL OR INDIRECT DAMAGES OF ANY KIND (WHETHER UNDER CONTRACT, TORT OR OTHERWISE) ARISING OUT OF: (I)

# Toshiba Corporation

THE USE OR INABILITY TO USE THE SOFTWARE, EVEN IF TOSHIBA, TOSHIBA'S AFFILIATES OR THEIR SUPPLIER HAS BEEN ADVISED OF THE POSSIBILITY OF SUCH DAMAGES; OR (II) ANY CLAIM BY A THIRD PARTY. SAVE AS SET OUT IN THIS SECTION, TOSHIBA'S ENTIRE LIABILITY UNDER THIS EULA SHALL NOT EXCEED THE PRICE PAID FOR THE SOFTWARE, IF ANY. THE ABOVE DISCLAIMER AND LIMITATION DOES NOT EXCLUDE OR LIMIT (A) LIABILITY FOR DEATH OR PERSONAL INJURY CAUSED BY NEGLIGENCE; OR (B) ANY MANDATORY LEGAL RIGHT OR LIABILITY TO THE EXTENT THAT IT CANNOT BE LAWFULLY EXCLUDED OR LIMITED UNDER APPLICABLE LAW. PLEASE MAKE AND RETAIN A COPY OF ALL DATA YOU HAVE INSERTED INTO YOUR PRODUCT, FOR EXAMPLE NAMES, ADDRESSES, PHONE NUMBERS, PICTURES, RINGTONES ETC, BEFORE SUBMITTING YOUR PRODUCT FOR A WARRANTY SERVICE, AS SUCH DATA MAY BE DELETED OR ERASED AS PART OF THE REPAIR OR SERVICE PROCESS.

6. **Laws.** This EULA will be governed by the laws of England and Wales. All disputes arising out of this EULA shall be subject to the exclusive jurisdiction of the English Courts.
7. **Export Laws.** Any use, duplication or employment of the Software involves products and/or technical data that may be controlled under the export laws of applicable countries or region and may be subject to the approval of the applicable governmental authorities prior to export. Any export, directly or indirectly, in contravention of the export laws of applicable countries or region is prohibited.
8. **Third Party Beneficiary.** You agree that certain suppliers of the Software to Toshiba have a right as a third party beneficiary to enforce the terms of this EULA against you as a user.
9. **Transfers.** The Software may be transferred only as installed on the Phone to a lawful third party user, where that party accepts the terms of this EULA which will continue to apply.
10. IF YOU ARE DEALING AS A CONSUMER IN THE UK & THE SOFTWARE QUALIFIES AS 'GOODS', YOUR STATUTORY RIGHTS UNDER APPLICABLE LAW ARE NOT AFFECTED.



# Toshiba Corporation

## EU Warranty

Your Toshiba phone contains no user serviceable parts. For further information on service please contact your retailer or service provider.



# Licenses

Licensed by QUALCOMM Incorporated under one or more of the following United States Patents and/ or their counterparts in other nations:

4,901,307 5,504,773 5,109,390 5,535,239

5,267,262 5,600,754 5,416,797 5,778,338

5,490,165 5,101,501 5,511,073 5,267,261

5,568,483 5,414,796 5,659,569 5,056,109

5,506,865 5,228,054 5,544,196 5,337,338

5,657,420 5,710,784

XT9 is trademark of Tegic Communications, Inc.  
Tegic Communications, an AOL Company.



Java™ and all Java-based marks are trademarks or registered trademarks of Sun Microsystems, Inc.



Bluetooth™ is a trademark of Bluetooth SIG, Inc. USA.



This miniSD™ logo is a Trademark.



## Licenses

Wi-Fi CERTIFIED is a Certification Mark of the Wi-Fi Alliance



PicseI, PicseI Powered, PicseI Viewer, PicseI File Viewer, PicseI Document Viewer, PicseI PDF Viewer and the PicseI cube logo are trademarks or registered trademarks of PicseI Technologies and/or its affiliates.



ArcSoft and the ArcSoft logo are registered trademarks of ArcSoft, Inc. in the United States, P. R. China, EU, and Japan.



Opera is a trademark or registered trademark of Opera Software ASA.  
Read more about Opera at <http://www.opera.com/>.



# Declaration of conformity

We, **Toshiba Information Systems UK (Ltd), Mobile Communications Division**, of **Toshiba Court, Addlestone Road, Weybridge, KT15 2UL** declare under our sole responsibility that this product (Portégé G500, Type (Model) Name RG4 - E01) is in conformity with the following standards and/or other normative documents:

**3GPP TS 51.010-1, 3GPP TS 34.121, EN 301 489-1, EN 301 489-7, EN 301-489-24, EN 300 328, EN 301 489-17, EN 60950 and EN 50360**

We hereby declare that all essential radio test suites, EMC & safety requirements have been carried out and that the above named product is in conformity to all the essential requirements of Directive 1999/5/EC. The conformity assessment procedure referred to in Article 10(5) and detailed in Annex IV of Directive 1999/5/EC has been followed with the involvement of the following Notified Body(ies):

**Cetecom GmbH, Im Teelbuch 122, 45219 Essen, Germany**

**CE 0682** 

6 March 2007



Takashi Okamoto  
Deputy Managing Director of TIU  
General Manager Mobile Communications Division



# Care and maintenance

## Care and maintenance

You can greatly enhance the life span of your Toshiba phone, and the parts and accessories, by following the suggestions below.

 **TIP:** Maintaining your Toshiba phone, and the parts and accessories, in a good condition will help you fulfil the warranty obligations.

- Keep your Toshiba phone and all the parts and accessories out of the reach of small children or pets.
- Keep your Toshiba phone dry, as moisture of any kind can contain minerals that will corrode the electronic circuits. The manufacturer's warranty may become invalid if our phone or battery were to get wet due to misuse.
- Do not use or store your Toshiba phone in dusty or dirty locations as the moving parts of the phone can be damaged.
- Do not use or store your Toshiba phone in hot areas. High temperatures will shorten the life span of the phone, damage the battery or warp/melt internal circuits.
- Do not store your Toshiba phone in cold areas. A big difference between room temperature and

the temperature in the phone can cause condensation to form inside the phone, causing damage to the electronic circuits.

- Do not keep your Toshiba phone in, or near, heat sources such as a radiator or microwave oven - this can cause the battery inside the phone to overheat and explode.
- Do not open your Toshiba phone unless absolutely necessary.
- Do not mishandle or abuse your Toshiba phone. Dropping the phone, knocking or shaking it can damage the internal circuits.
- Do not use harsh chemicals, strong detergents, or cleaning solvents to clean your Toshiba phone. Use a soft, clean, dry, lint-free cloth to clean the phone.
- Do not use water to clean the LCD screen.
- Do not apply paint or other such substances to your Toshiba phone.
- If your Toshiba phone, or any of the accessories, are not working as they should, please consult your dealer who can provide you with the expert assistance you require.
- Do not use excessive volume levels when using headphones.





## Care and maintenance

- If your Toshiba phone has a flash unit, do not operate the flash too close to a person's eyes - this may cause damage to their eyes.
- Interference may affect the performance of your Toshiba phone. This is normal and the phone should operate as usual once you move away from the source of the interference.
- Do not attempt to disassemble your Toshiba phone. Only Toshiba authorised personnel should service the phone.

### Restarting your Toshiba phone

1. Remove the battery (see **Getting started** section for instructions).
2. Re-insert the battery and turn your Toshiba phone on (see **Getting started** section for instructions).



**IMPORTANT:** If you restart your Toshiba phone while a program is running, data that you have not saved will be lost.

### Hard resetting your Toshiba phone

You should only use this procedure as a last resort. If you are experiencing a problem with an application, it is most likely a result of a conflict between installed programs. We recommend uninstalling the most recently added program first. Also verify that the program is designed to be run on your Toshiba phone by comparing the requirements to the information provided with your phone - select **Start > Settings > More... > About** to view this information.



**NOTE:** Hard resetting your phone will delete all your applications. You will also lose all personal data such as music, ringtones and pictures. You are advised to back up all your data before hard resetting your phone.

To hard reset your phone:

1. Select **Start > Settings > More... > Format User Partition.**
2. Follow the on-screen instructions to reset your phone.
3. Your phone will restart after it has been reset.



# Safety instructions

## Wireless LAN security

It is possible for an outside party to easily gain unlawful access to your Toshiba phone via Wireless LAN if the security function is not used.

Without this security, your Toshiba phone carries the risk of unlawful access, wiretapping, and loss or destruction of data.

You should set up your Toshiba phone to use the authentication and encryption features (WEP, WPA) in order to prevent such access.

When using a public Wireless LAN access point, your Toshiba phone should be protected from unlawful access by the Windows firewall of Windows Security Centre and the anti-virus software within the firewall feature.

## Bluetooth security

Although your Toshiba phone has security features compliant with the Bluetooth standard specification, this security might not work properly when using your Toshiba phone in a non-secure environment. Please take care when using the Bluetooth feature.

## FCC notice

This device complies with Part 15 of the FCC rules. Operation is subject to the following two conditions:

(1) This device may not cause harmful interference, and (2) This device must accept any interference received, including interference that may cause undesired operation.

Changes or modifications not expressly approved by the party responsible for compliance could void the user's authority to operate the equipment.

# Safety instructions

## Information to user

This equipment has been tested and found to comply with the limits of a Class B digital device, pursuant to Part 15 of the FCC Rules. These limits are designed to provide reasonable protection against harmful interference in a residential installation. This equipment generates, uses and can radiate radio frequency energy and, if not installed and used in accordance with the instructions, may cause harmful interference to radio communications. However, there is no guarantee that interference will not occur in a particular installation; if this equipment does cause harmful interference to radio or television reception, which can be determined by turning the equipment off and on, the user is encouraged to try to correct the interference by one or more of the following measures:

1. Reorient/relocate the receiving aerial.
2. Increase the separation between the equipment and receiver.
3. Connect the equipment into an outlet on a circuit different from the outlet the receiver is currently connected.

4. Consult the dealer or an experienced radio/TV technician for help.



**WARNING:** Changes or modifications not expressly approved by the manufacturer responsible for compliance could void the user's authority to operate the equipment.



# Getting Started

## Unpacking

Please ensure that the contents of your sales pack include:

- **Your Toshiba phone**
- **AC adapter**
- **AC cable**
- **Battery pack**
- **USB cable**
- **Earphones**
- **User guide**
- **CD**





# Getting Started

## Phone layout and functions

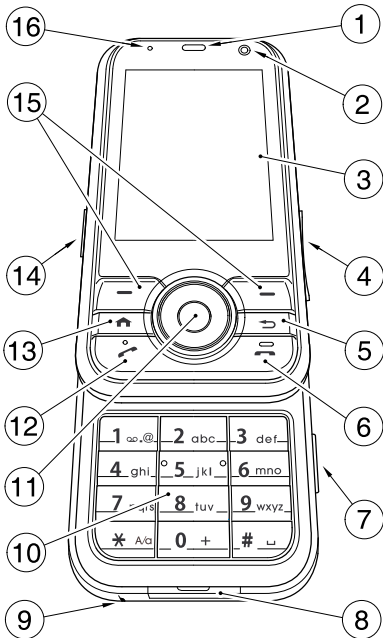

1. **Earpiece**
2. **Front camera**
3. **Main display**
4. **Side key** - adjusts the volume.
5. **Back/Delete key** - returns to the previous screen or used to delete a text entry.
6. **End key** - ends calls/operations and returns to standby mode.
7. **Camera key** - launches **Camera**.
8. **Cable and phone charging connector**
9. **Microphone**
10. **Keypad** - enters phone numbers and characters.
11. **Navigation key/Action key** - moves the cursor up, down, left or right, confirms operations and accesses shortcuts. The **Action** key is used to open the selected operation.
12. **Send key** - launches the phone pad mode whilst in standby mode. Makes and answers calls.
13. **Home key** - returns to **Home** screen.
14. **Headset connector**
15. **Right and Left Softkey** - performs operations indicated on the main display.
16. **Power LED** - bi-colour LED Power indicator, battery charging status.

# Getting Started

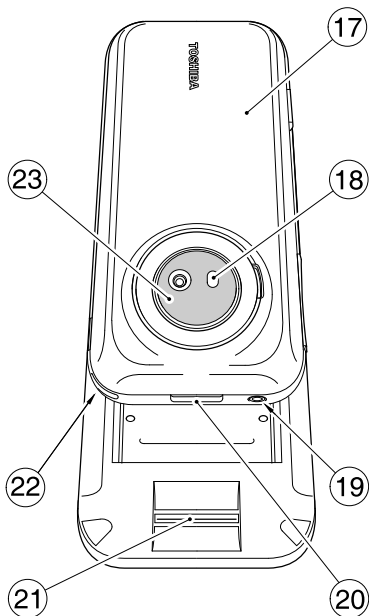

- 17. **Battery cover**
- 18. **Camera flash**
- 19. **Power key** - turns power on/off.
- 20. **Cover lock button** - locks and unlocks battery cover.
- 21. **Fingerprint sensor**
- 22. **Handstrap hole**
- 23. **Rear camera**

# Getting Started

## Home screen

You can access the Home screen from any menu by pressing the **Home** key. Important information such as date, time, status indicators, appointments and profile are displayed on the **Home** screen. You can open a program directly by selecting the relevant icon and pressing the **Action** key.



**NOTE:** Access the **Settings > Home screen** menu to change the **Home** screen layout.

1. Recently-used programs are displayed here. Select an icon to run a program again.
2. Displays the name of your wireless service provider.
3. Displays the time and date.
4. Displays appointments.
5. Select to view details of missed calls.
6. Displays your current profile.
7. Select to read new text messages.
8. Select to display all program icons.
9. Displays the status indicators (described below).
10. Select to open messages, **Contacts** or **Call History**. The name of this button is dynamic and depends on previous activity on the phone.























# Getting Started

## Display indicators

Slot	Type	Icon	Description
1	Missed call icon		Missed call
2	Voice mail icons		New Voicemail(s)
			New Voicemail(s)
			Voicemail on line1
			Voicemail on line2
			Voicemail on both lines
3	Notification icons		New e-mail(s) or text message(s)
			New instant message(s)
			Incoming beam
			New OTA (OTA: Over The Air)
			Bluetooth
			SIM Error
			Sync error
4	Call forward icons		Call forwarded
5	Roaming icons		Roaming
		<b>G</b>	GPRS in range
			GPRS Roaming
		<b>1X</b>	CDMA in range (not supported)
		<b>E</b>	EDGE in range
			EDGE Roaming
		<b>3G</b>	3G in range









# Getting Started

Slot	Type	Icon	Description
			3G Roaming
6	Phone line icons	1	ALS 1
		2	ALS 2
7	Volume icons		Vibrate
			Ringer Off
8	Radio signal icons		Wi-Fi network in range
			Wi-Fi connected SP
9	Battery strength icons		Battery level
			Battery alert
			Battery charging
			Low battery
		Text input mode (Only in Editor mode)	
		XT9 mode, upper case	
		XT9 mode, caps lock	
		ABC mode, lower case	
		ABC mode, upper case	
		ABC mode, caps lock	
		Number mode	
0	Signal strength icons		Signal strength
			Voice/Video Call in progress
			Data call in progress
			GPRS in progress
			3G in progress





# Getting Started

Slot	Type	Icon	Description
			EDGE in progress
			Radio No signal or Radio On Hold
			Radio off
			Radio no service
			Dialling
			Call on hold
			No SIM card installed



# Getting Started

## Installing the SIM card, battery and miniSD card

**i** **IMPORTANT:** The SIM card is easily damaged by scratching and bending, so take care with handling it.

- Press the **Cover Lock** button (1) down, lift the battery cover (2) upwards and remove the battery from the battery compartment.

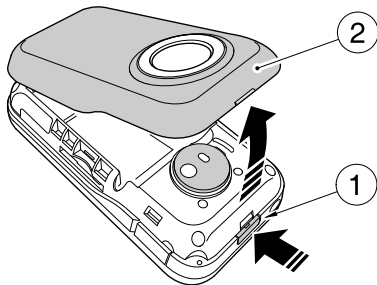

- With the gold connectors facing downwards, align the bevelled corner of the SIM card with the bevelled corner in the SIM card holder. Push down lightly and slide the SIM card (3) into place.

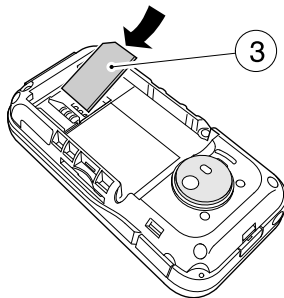

# Getting Started

- Insert the battery into the battery compartment with the gold connectors facing downwards. Gently push down to snap into place.

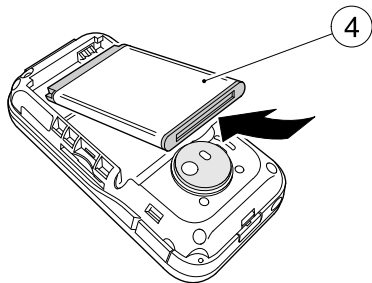

- Gently click battery cover (2) into position.

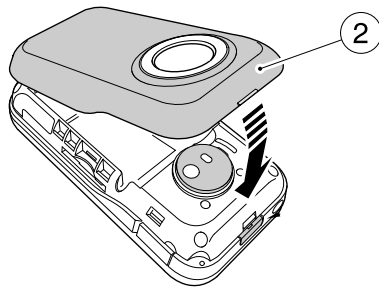

# Getting Started

- Slide the miniSD card into the miniSD slot (5).

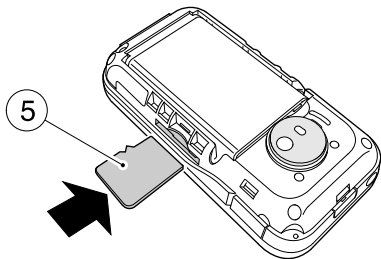

- To remove, press miniSD card inwards (5). The miniSD card will pop out (6).

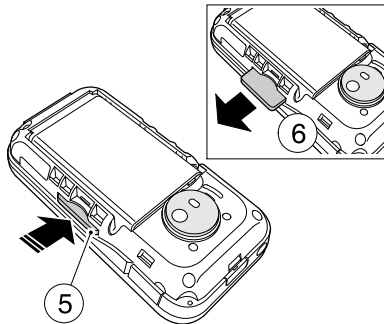

# Getting Started

## Charging the battery

You need to fully charge the battery before you can switch your Toshiba phone on for the first time. The battery will only achieve optimum performance after two or three complete charges.

You can charge your battery in the following two ways:

1. Plug the AC adapter into an AC outlet and connect to the charger connector on your Toshiba phone. When the battery is fully charged, unplug the AC adapter from the AC outlet and disconnect it from the phone charger connector by gripping tightly and pulling gently.

or

2. .Connect your Toshiba phone to a PC with the USB cable. Ensure that your Toshiba phone is on before connecting it to your PC.



**TIP:** To check your battery status, select **Start > Settings > Power Management**.

## Low battery indicator

When the battery charge level is running low, a warning tone sounds and the Battery Low message is displayed repeatedly. If the battery charge level runs too low for normal operation, your Toshiba phone will automatically switch off.

## Battery information

Battery performance depends on many factors, such as your Service Provider's network configuration, signal strength, the temperature of the environment in which you operate your Toshiba phone, the features and/or settings you select and use, items attached to your phone's connecting ports, and your voice, data, and other program usage patterns.

## Checking the battery power

From the **Home** screen, select **Start > Settings > Power Management**.

## Optimizing the power performance

From the **Home** screen, select **Start > Settings > Power Management**, and adjust the backlight, display, and Wi-Fi settings.





# Getting Started

## Managing a low battery

When the low battery warning is displayed, do the following:

1. Save your current data.
2. Synchronize with your PC to charge the battery.
3. Turn your Toshiba phone off.



**WARNING:** There is a danger of explosion if the battery is incorrectly replaced. To reduce risk of fire or burns, do not disassemble, crush, puncture, short external contacts, expose to temperature above 60°C (140°F), or dispose of battery in fire or water. Replace only with specified batteries according to the local regulations.

## Switching the power on and off

To switch your Toshiba phone on:

1. Press and hold down the **Power** key. The stand-by screen is displayed.
2. If a PIN or security code is requested, enter the code.

To switch your Toshiba phone off, press and hold down the **Power** key.



**NOTE:** The PIN code activates the services in your Toshiba phone and should be provided in the documentation supplied by your service provider.

## Synchronizing

ActiveSync allows you to create a synchronization relationship between your Toshiba phone and PC, and between your Toshiba phone and your Exchange server. This means that the shared data is always consistent. If you make a change, it is automatically made to the corresponding information on the other computer. This is an effective way of keeping your data up-to-date.

You can connect to your PC using the USB cable or Bluetooth connection. You can also use ActiveSync to connect your Toshiba phone to other resources through your PC. However, you cannot synchronize remotely to a PC using a modem or network connection. The synchronization relationship is created to manage the data that is copied between your Toshiba phone and PC.

# Getting Started

You can connect to your Exchange server using a cellular connection, or you can connect your Toshiba phone to your PC as a way of connecting back to the Internet.

## Installing and setting up ActiveSync

You can either install ActiveSync from your Windows Mobile Getting Started CD or you can download a copy of ActiveSync from <http://www.microsoft.com/windowsmobile/addons/default.aspx>

Once the software has been installed and your Toshiba phone is connected to your PC, via the USB cable, the ActiveSync Setup Wizard is started. Simply follow the on-screen instructions.

 **NOTE:** If you have a PC which is already fully synchronized with your Exchange server, you should synchronize your Toshiba phone to your PC rather than synchronizing your Toshiba phone with the Exchange server. Data will be downloaded via your PC, saving you the charges for traffic volume. In addition, synchronizing via your mobile phone network will take longer than it would with your local PC.

If you are not synchronizing directly with a Microsoft Exchange server, do not select the option to synchronize directly with a server. The alternative is to synchronize your Toshiba phone with your PC. You cannot do both at the same time.

## Changing ActiveSync settings

Once you have set up synchronization using the ActiveSync Setup Wizard on the PC, you can change your synchronization settings at a later stage:

- If you want to change ActiveSync settings for synchronizing with a PC, use ActiveSync on the PC. For more information, see 'Changing the amount of information synchronized' in ActiveSync Help on the PC.
  - If you want to change ActiveSync settings for synchronizing with an Exchange server, use ActiveSync on your Toshiba phone, as described in 'Change settings for an information type.'
-  **NOTE:** Disconnect your Toshiba phone from your PC before changing the synchronization settings.





# Getting Started

## Starting/stopping synchronization

1. On the **Home** screen, select **Start > ActiveSync**.
2. To start synchronization, select **Sync**.
3. To stop synchronizing, select **Stop**.

## Synchronizing Media

Your Toshiba phone can synchronize media from your PC, such as music and video files. This is described in detail in **Applications & Multimedia**.



**NOTE:** You can only start/stop synchronization if your Toshiba phone already has a synchronized relationship with a PC or Exchange server.



# Call Functions

## Making a call

You can make calls from the **Home** screen, **Phone** screen, **Contacts**, **SIM contacts** or **Call History** menus, or via speed dial.

Before making a call, ensure that your Toshiba phone is switched on, that there is a valid SIM card installed, and that the signal is sufficiently strong. To make a call, enter the phone number from the **Home** screen using the numeric keypad, or press the **Send** key and scroll down the list to the required number.

Press the **Send** key to dial.

## Making an emergency call

You can make calls to emergency service numbers under almost any circumstances, even if you have locked your Toshiba phone or if you have not enabled your SIM.

## Making a call by entering a contact name

1. From the **Home** screen, enter the initial letters of the contact name.

2. A list of contacts matching your keystrokes is displayed. Select the relevant contact and press the **Send** key once or the **Action** key twice.

## Making a call from an open contact

1. From the **Home** screen, select **Start > Contacts**.
2. Select the contact and relevant phone number.
3. Press the **Send** or **Action** key.

## Making a call from Contacts

1. From the **Home** screen, select **Start > Contacts**.
2. Select the contact, and press the **Send** key.



**TIP:** If you have a long list of contacts, you can use a shortcut to find the contact you want: enter the first few letters of the contact's name. The phone searches through the contact list and displays the name. To call the contact, press the **Send** key.

Alternatively, if displayed on the **Home** screen, you can access your contacts by pressing the right softkey from the **Home** screen.





# Call Functions

## Assigning the number

You can assign a work phone number (w), mobile phone number (m) and a home phone number (h) to a contact. The mobile phone number is dialed by default, unless you expand the list and scroll down to the phone number required.

## Making a call from Call History

Call History displays calls you have made, received, and missed recently.

1. From the **Home** screen, select **Start > Call History**.
2. Select the relevant name or phone number.
3. Press the **Send** key.

## Making a call using a recently dialed phone number

1. From the **Home** screen, press the **Send** key.
2. Select the relevant name or phone number.
3. Press the **Send** key.

## Dialling the last number called

From the **Home** screen, press the **Send** key twice.

## Creating a speed dial

You can create a speed dial for a phone number, e-mail address or web page address that is stored in your Contacts directory.

To create a speed dial entry:

1. From the **Home** screen, select **Start > Contacts**.
2. Select the contact.
3. Select the phone number, e-mail address, text message, or web page address.
4. Select **Menu > Add to Speed Dial**.
5. In **Keypad assignment**, select the speed dial number.
6. Select **Done**. The speed dial entry is created.



**NOTE:** The digit **0** is reserved to bring up the + symbol in international dial strings when you press and hold **0**. The digit **1** is reserved for calling your voice mail box as a speed dial option.

# Call Functions

## Voice mail speed dial

The voice mail speed dial is normally preconfigured. If it is not preconfigured, you can save your voice mail number by selecting **Start > Settings > Phone > Call Options > Voice mail number** and create a speed dial entry, as explained above.

Contact your Service Provider to access the voice mail number.

## Using a speed dial

From the **Home** screen, press and hold the speed dial number you want to call. If the speed dial contains two digits, press the first digit, then press and hold the second digit. Your Toshiba phone dials the phone number, displays the new e-mail message, or opens the desired web page.

## Editing a speed dial

1. From the **Home** screen, select **Start > More > More > Speed Dial**.
2. Scroll to the relevant speed dial, press the **Action** key > select **Edit**.
3. Make the necessary changes and select **Done**.

## Deleting a speed dial

1. From the **Home** screen, select **Start > More > More > Speed Dial**.
2. Scroll to the relevant speed dial and select **Menu > Delete**.

## Receiving a call

### Answering or ignoring a call

- To answer an incoming call, press the **Send** key or select **Answer**.
- To ignore an incoming the call, press the **End** key or select **Ignore**.

**NOTE:** If you choose to ignore a call, the caller will be connected to your voice mail, provided you have subscribed to this service.

### Answering a call by pressing any key

The **Send** key is the default key to answer an incoming call. To override this and use any button to answer instead, do the following:

1. From the **Home** screen, select **Start > Settings > Phone > Call Options**.





# Call Functions

2. Scroll to **Any key answer** and press the **Action** key. A tick is placed in the box.
3. Select **Done**.

## In-call options

### Answering or postponing a second call

To answer or postpone a second call, you need to first enable the call waiting option by doing the following:

1. From the **Home** screen, select **Start > Settings > Phone > Call Waiting**.
2. Press the **Action** key. A tick is placed in the box.
3. Select **Done**.

Once the call waiting option has been enabled on your Toshiba phone and the settings have automatically been sent and accepted by your Service Provider, you will receive an audible and visual notification on your Toshiba phone if another call comes in during your current call.

- To put the first call on hold and answer the second call, press the **Send** key. To switch between calls, select **Swap**.

- To avoid answering the call, select **Ignore**. The second call will either be disconnected or diverted to voice mail, if you have subscribed to this service.

### Making a second call while already in a call

1. Whilst in a call, select **Menu > Hold** to place the call on hold.
2. Dial the second number and press the **Send** key. Your first call will remain on hold.
3. To swap between the two calls, press the **Send** key or select **Menu > Swap**.

### Joining two or more calls together in a conference call

1. With two calls active on your Toshiba phone, one active and the other on hold, select **Menu > Conference**. The two calls will be joined together and each party will be able to hear the other.

# Call Functions

## Adding an additional party to the call

1. To add another party to the conference call, dial another person, again selecting **Menu > Conference**.

## Having a private conversation with a party

1. To do this you will need to split the conference call up. With the conference call running, select **Menu > Private**.
2. Select the party with whom you wish to have the private conversation and press the **Action** key.

**NOTE:** The conference call feature depends on your Network Provider supporting it. Please check with your Network Provider to ensure you can use this feature.



## Placing a call on speakerphone

1. Whilst in a call, select **Menu > Speakerphone On**. The speakerphone is activated.
2. To switch the speakerphone off, select **Menu > Speakerphone Off**.



**NOTE:** The speakerphone mode will not be automatically enabled in your next call, even if you left the function switched on in the previous call.

## Special dialling requirements

### Inserting a manual pause in a dialling sequence

Calls to certain networks may require a pause between the dialled digits. To do this:

1. From the **Home** screen, select **Start > Contacts**.
2. Select the contact number in which you want to insert a pause and select **Menu > Edit**.
3. Place the cursor where you want to insert the pause.
4. Select **Menu > Insert Wait**. The letter **w** is displayed where the manual pause will occur in the dialling sequence.
5. Select **Done**.





# Call Functions

## Inserting an automatic pause in a dialling sequence

Some international calls may require a pause in the dialling sequence.

1. From the **Home** screen, select **Start > Contacts**.
2. Select the contact number in which you want to insert a pause, and then select **Menu > Edit**.
3. Place the cursor where you want to insert the pause.
4. Select **Menu > Insert Pause**. The letter **p** appears where the automatic pause will occur in the dialling sequence.
5. Select **Done**.

## Inserting an international country code

To make an international call, you must include a country code at the beginning of the dialling sequence.

To enter the country code, press and hold the digit **0** until a **+** sign is displayed, and then enter the rest of the phone number.



**NOTE:** Similarly, you can insert a **+** sign when saving a contact's phone number or dial it directly from the keypad.

## Video telephony

Video calls allow you to enjoy live 'face-to-face' conversations with friends, family and colleagues.

### Making a video call

Before making a video call, you must confirm that the person you are video calling also has a video-enabled phone. To make a video call:

1. From the **Home** screen, press the **Send** key.
2. Enter the phone number.
3. Select **Menu > Video Call**. The video call is made.

# Call Functions

## Answering or ignoring a video call

- To answer an incoming call with video enabled, select **Answer**.
- To answer an incoming call with video blocked, press the **Send** key. An image will be sent according to the current Video Call Settings (refer to the Settings section for further information).
- To ignore an incoming the call, press the **End** key or select **Ignore**.

## Answering a video call by pressing any key

The **Send** key is the default key to answer an incoming video call. To override this and use any button to answer instead, do the following:

1. From the **Home** screen, select **Start > Settings**.
2. Select **Phone > Call Options**.
3. Scroll to **Any key answer** and press the **Action** key. A tick is placed in the box.
4. Select **Done**.



**NOTE:** Video call and Wireless LAN (Wi-Fi) do not work simultaneously.

- You cannot receive a video call when Wi-Fi is on. The incoming video call will be treated as a Missed Call.
- You cannot turn on Wi-Fi during a video call.

## Call history

### Making a call from Call History

Call History displays calls you have made, received, and missed recently.

1. From the **Home** screen, select **Start > Call History**.
2. Select the relevant name or phone number.
3. Press the **Send** key.

### Deleting an item from Call History

1. From the **Home** screen, select **Start > Call History**.
2. Select the item to delete.
3. Select **Menu > Delete**. The item is deleted.





# Call Functions

## Delete all items in Call History

To delete all items in Call History, select **Start > Call History > Menu > Delete List**.

## Finding a contact from Call History

1. From the **Home** screen, select **Start > Call History**.
2. Select a call to, or from, the contact.
3. Select **Menu > Find Contact**.

## Creating a contact from Call History

1. From the **Home** screen, select **Start > Call History**.
2. Select the phone number for which to create a contact, and then select **Menu > Save to Contacts**.
3. Select **<New Item>**.
4. Select **Insert** to insert the phone number.
5. Enter the remainder of the contact information and select **Done**. The new contact is saved in your contact list.

## Viewing a Call History by filtering

To view missed calls, incoming calls, and outgoing calls separately, select **Menu > Filter**, and select the type of calls to view.



# Messaging

This chapter describes how you can create, send, receive, organise, delete and store the following message types on your Toshiba phone:

- Text (SMS, Short Message Service) message
- Outlook email
- Multimedia message (MMS)

You can also use the instant messaging application, MSN Messenger, from your Toshiba phone. This application enables online over-the-air chat, as well as providing access to your MSN Hotmail email account.

## Text (SMS) messaging

### Creating a Text (SMS) message

Text messaging, or the Short Message Service (SMS), allows you to exchange text messages with other phones. For details on text messages, contact your Service Provider. Your Toshiba phone supports the sending of more than the standard 160-character limit. If you enter more than 160 characters, the message is split into linking SMS messages. You can send multiple linked SMS messages at one time.

To create and send a Text message:

1. From the **Home** screen, select **Start > Messaging > Text message > New**.
2. Select an existing contact by selecting **Menu > Add Recipient**.



**TIP:** To enter phone numbers quickly from your contact list, simply press the **Action** key while the cursor is in the **To** field.

3. Alternatively, enter the mobile phone number of the recipient/s in the **To** field. Use a semicolon to separate multiple recipients.
4. After you have selected your recipient/s, scroll down to the message area and enter your message.
5. Select **Send**. The Text message is sent.



**TIP:** To delete a message, select **Menu > Cancel Message** whilst in the **Text Message** creation screen.

### Delivery notification

To request Delivery notification:

1. Select **Menu > Message Options** whilst in the **Text Message** creation screen.





# Messaging

2. Press the **Action** key to check the **Request message delivery notification** box.
3. Select **Done**. Your request is sent to your Service Provider.

## Inserting predefined text into a message

To save time when entering text, you can insert predefined text into a message:

1. From the **Home** screen, select **Start > Messaging > Text message > New > Menu > My Text**.
2. Select the text you want to insert by entering the corresponding number.

## Replying to a message

1. From an open message, select **Reply**.  
If you are replying to a number of recipients, select **Menu > Reply All**.
2. Enter your message in the message area.
3. Select **Send**. The Text message/s is sent.

## Forwarding a message

1. From an open message, select **Menu > Forward**.
2. Select an existing contact by selecting **Menu > Add Recipient**.



**TIP:** To enter phone numbers quickly from your contact list, simply press the **Action** key while the cursor is in the **To** field.

Alternatively, enter the mobile phone number of the recipient/s in the **To** field. Use a semicolon to separate multiple recipients.

3. If necessary, enter a message in the message area.
4. Select **Send**. The Text message is sent.

## Deleting a message

1. From the **Home** screen, select **Start > Messaging > Text Message**.
2. Select the message to delete and select **Menu > Delete**.

# Messaging

## Email

Before you can send or receive emails, you need to set up an email account. Your Toshiba phone supports the following types of email accounts (all of which are covered in this section):

- Internet email (POP3/IMAP)
- Exchange server (Outlook)

### Setting up an email account automatically

1. From the **Home** screen, select **Start > Messaging > New Account**.
2. Select **Other (POP3/IMAP)** from the **Your email provider** field. Select **Next**.
3. Enter your display name for email messages in the **Your name** field. Press the **Action** key to confirm your entry.
4. Scroll down to the **Email address** field and enter the email address for this account. Press the **Action** key to confirm your entry.
5. Scroll down to the **Automatic setup** field and press the **Action** key to check the **Attempt to obtain email settings from the Internet** box.

6. Select **Next**.
7. If the account is set up successfully, you are prompted to send and receive email. If the account is not set up successfully, you must select **Next** and set up the account manually, as described in the following section.

### Setting up an email account manually

1. Enter a user name in the **User name** field. This is usually the first part of your email address, which appears before the sign '@' sign. Press the **Action** key to confirm your entry.
2. Scroll down to the **Password** field. Enter a password in the **Password** field.  
**TIP:** Choose a strong password - strengthen the security of your password by selecting a combination of word and number characters.





Press the **Action** key to confirm your entry.

3. You will have the option to save your password so you do not need to enter it each time you connect to your email server.





# Messaging

4. Scroll down to the **Domain (if necessary)** field. Enter the domain name. Press the **Action** key to confirm your entry.  
This may or may not be required. Contact your Internet Service Provider for more information.
5. Scroll down to the **Save password** field. Press the **Action** key to check the box, if you wish to save your password to your Toshiba phone.  
 **WARNING:** If you save your password and then lose your Toshiba phone, you run the risk of someone else being able to access your email account.
6. Select **Next**.
7. Select the server type that hosts your email mailbox, in the **Server type** field (POP3 or IMAP).
8. Scroll down to the **Account name** field. Enter a unique name for this account (you must use a different name for each account that you set up). Press the **Action** key to confirm your entry.
9. Scroll down to the **Network** field. Select the network to which your email server connects.
10. Select **Next**.
11. Enter the name of the incoming server in the **Incoming Server** field (POP3 or IMAP4). Press the **Action** key to confirm your entry.
12. Scroll down to the **Require SSL connection** field.  
 **IMPORTANT:** The SSL connection enables you to receive personal information more securely. Please note that if you select this option and your ISP does not support an SSL connection, you will not be able to connect and receive email.  
Press the **Action** key to check the box, if you wish to enable the SSL connection.
13. Scroll down to the **Outgoing Server** field. Enter the name of your outgoing email server (SMTP). Press the **Action** key to confirm your entry.
14. Scroll down to the **Outgoing server requires authentication** field.  
 **IMPORTANT:** Your outgoing email server (SMTP) may require authentication. If authentication is required, your user name and password (as specified above) will be needed. Contact your Service Provider for more information.

# Messaging

Press the **Action** key to check the box, if the outgoing server requires authentication.

15. Scroll down to the **Outgoing Server Settings** field. Your outgoing email server may require different authentication settings than your incoming email server. Press the **Action** key, the Outgoing Server Settings are displayed.

Check the **Use different user name for outgoing server** box to enter separate settings for your outgoing email server. Simply press the **Action** key to check the box.

Scroll down to the **User name** field. Enter your user name for the outgoing email server. Press the **Action** key to confirm the entry.

Scroll down to the **Password** field. Enter your password for the outgoing email server. Press the **Action** key to confirm the entry.

Scroll down to the **Domain (if necessary)** field. Enter the domain name of the outgoing email server. Press the **Action** key to confirm the entry.

Scroll down to the **Save password** field. Press the **Action** key to check the box, if you wish to save your password to your Toshiba phone.



**WARNING:** If you save your password and then lose your Toshiba phone, you run the risk of someone else being able to access your email account.

Scroll down to the **Require SSL connection** field.



**IMPORTANT:** The SSL connection enables you to send personal information more securely. If you select this option and your ISP does not support an SSL connection, you will not be able to send email.

Press the **Action** key to check the box, if you wish to enable the SSL connection.



**IMPORTANT:** Before you set up your Internet email account, ensure that you have the necessary information, as listed above.

## Completing the set up of your email account

1. From the **Home** screen, select **Start > Messaging**, and select an email account.



# Messaging

2. Select **Menu > New Account > Other (POP3/IMAP) > Next**.
3. Enter your display name for email messages in the **Your name** field.
4. Enter the email address for this account in the **Email address** field.
5. Select **Next**.
6. Select **Finish**.

## Setting up an Outlook email account

An Outlook email account is created and managed by Microsoft's Exchange server. You must have this account set up before continuing with the other steps described in this section.

To send or receive email messages with your exchange server, select **Start > ActiveSync**. You will receive a prompt if your exchange server is qualified to install the feature called MSFP (Microsoft Messaging and Security Feature Pack). For example, Exchange Server 2003 with SP2 has the option to install this. One of the benefits of installing MSFP is the Server's ability to send through new emails as they arrive to the Outlook client in your Toshiba phone.

Once the ActiveSync completes successfully, select **Start > Messaging > Outlook Email > Menu > Folders**. The email folders are similar to the Outlook client in a PC.

## Viewing your Inbox message list

From the **Home** screen, select **Start > Messaging**, and select an account. The Inbox message list displays your received messages.

## Create an email message

1. From the **Home** screen, select **Start > Messaging**.
2. Select an email account.
3. Select **New**.
4. In the **To**, **CC**, and/or **BCC** field, enter the recipient's email address/es. Insert a semicolon between multiple addresses.
5. Enter a subject in the **Subject** field.
6. Enter a message.



# Messaging

7. Select **Send**. Email messages are stored in your Outbox and are sent to recipients the next time you synchronize or connect to your email server.



**TIP:** You can quickly enter email addresses from your contact list. Whilst in the **To** field, press the **Action** key and select a recipient from the list. Select the recipient's email address. The semicolon separator is automatically inserted if you enter multiple recipients.

To set the priority of the email, select **Menu > Message Options**.

To cancel a message, select **Menu > Cancel Message**.

## Inserting predefined text into an email message

Please refer to the **Text (SMS) messaging** section for details on how to use this facility. It can be used when creating a new message or replying to an email.

## Creating and adding a signature to an email message

For each account in Messaging, you can specify a signature to be automatically inserted into messages that you send.

1. From the **Home** screen, select **Start > Messaging** and select an account.
2. Select **Menu > Options > Signatures**.
3. Scroll to the account for which you are creating the signature.
4. Select **Use signature with this account**.
5. To insert a signature in every message you send, select **Include when replying and forwarding**. Otherwise, a signature is inserted in new messages only.
6. Select the **Signature** box, enter your signature.
7. Select **Done**.

## Replying to an email message

1. From an open message, select **Reply** or, if replying to multiple recipients, select **Menu > Reply All**.
2. Enter a message in the message area.



# Messaging

3. Select **Send**.



**TIP:** If you are replying to an email in the Outlook Email account, you will send less data if you do not edit the original message. This may reduce data transfer costs based on your rate plan.

## Sending and receiving email messages

1. From the Home screen, select **Start > Messaging**.
2. Select the email account that you want to send and receive messages.
3. Select **Menu > Send/Receive**. Your Toshiba phone connects to your Internet email server and sends and receives your messages.

## Downloading a complete email message

1. From the **Home** screen, select **Start > Messaging** and select an account.

2. Select the message to download.



**NOTE:** To stop this process, select **Menu > Stop Send/Receive**.

3. Select **Menu > Download Message**. The complete message is retrieved the next time you synchronize or connect to your email server to send/receive email.

## Downloading an email attachment

In an open message with an attachment to download, select the attachment. The attachment is downloaded the next time you synchronize or connect to your email server and send/receive email.



**NOTE:** Alternatively, you can scroll down to the bottom of the email message and select **Get the rest of this message**.

## Viewing an attachment

In an open message containing a downloaded attachment, select the attachment.



# Messaging

## Adding a picture to an email message

1. In the message area of an email message, select **Menu > Insert > Picture**.
2. Select the picture you want to add.

 **NOTE:** You can only view attachments for file types that are supported by your Toshiba phone.

## Digitally signing a message

Digitally signing a message applies your certificate with the public key to the message. This provides the recipient with proof that the message is from you and not an imposter, and that the message has not been altered. To digitally sign a message:

1. In the message list, select **Menu > Switch Accounts > Outlook Email**.
2. Select **New > Menu > Message Options > Sign message > Done**.

 **NOTE:** S/MIME encryption and digital signatures for Windows Mobile-based devices are available only with Exchange Server 2003 Service Pack 2 or a later version that supports S/MIME. If you are not using one of these products, or have not yet synchronized, these options will not be available.

## Switching between email folders and accounts

1. Select **Start > Messaging > Outlook Email > Folders**.
2. Select the new folder you wish to view.

## MMS messaging

The Multimedia Messaging Service (MMS) allows you to exchange multimedia messages containing data such as text, pictures, sounds, animation and video clips. You can send MMS messages to other mobile phones or to email addresses. For details on MMS, and to enable your account for this service, contact your Service Provider.



# Messaging

An MMS can be made of many pages, also known as 'slides'. Each slide can hold an image, a sound and text, but you do not need to set all of these for each message. The maximum amount of content that can be sent in a message is set by your Service Provider.

## Creating an MMS

1. From the **Home** screen, select **Start > Messaging** and select the **MMS** option.
2. On the MMS main screen, select **New** to create a new MMS.
3. Add a recipient.

You can enter a phone number directly into the **To** field, or you can select a contact from your contact list. To choose a contact select **Menu > Recipients > Add**. The MMS composer is able to deliver the message to more than one user. When delivering to multiple recipients, input a semicolon between recipients.

## Adding a Picture or Video

To add an image to the message:

1. Select the **Insert Picture/Video...** area. The preview of all pictures and videos in the current folder is displayed.
2. Select one of the pictures in the current folder. To launch the camera application, select **Menu > Capture Picture** or **Menu > Capture Video**.
3. Once you have selected a picture or video, the main message is displayed.



**NOTE:** If you add a video to the message, you cannot add any further audio to the slide.

## Adding text to the MMS message

Select the **Insert Text...** area and enter your message. To use predefined text, select **Menu > Insert Media > My Text** whilst in the **Insert Text...** area.

## Using/creating templates

Select **Menu > Template** and choose a template to use or create a new one yourself.

# Messaging

## Selecting a message background colour

To choose the message background colour, select **Menu > Options > Background**. A list of colours is displayed.

## Additional items

Just as for email, you may add recipient/s in copy (cc) or blind copy (bcc) to your message. You may also set the priority of the message, a delivery time delay for the sending of the message, an expiry time for the message, and request delivery and read report/s.

To set these requirements, go to **Menu > Options > Send Options...** and set all these options as required

## Receiving MMS messages

Your Toshiba phone will alert you when a new MMS arrives. Depending on your settings, the MMS contents may download a few moments later when the message will be ready to view in your MMS Inbox.

The MMS Inbox functions in an identical way to your email and text message inboxes.

## MMS settings

- **Delete** - deletes current message.
- **Reply** - replies to all and forwards current message.
- **Folders** - switches to other folders (including Drafts, Outbox, Inbox, Sent Items and Deleted Items).
- **Switch Accounts** - switches between Text Message, Outlook Email and MMS.
- **Move** - moves current message into another folder.
- **Mark as Read/Unread** - marks current item as unread/read.
- **Download Message** - if you have chosen only to take notification of MMS messages, and not to download the whole MMS message, you can mark a message for download. The MMS message will be downloaded when you next send or receive a message.
- **Options** - changes the account options for the MMS account.
- **Send/Receive** - forces a send/receive of MMS messages that are pending.



# Messaging

## Setting up the MMS account

If your Toshiba phone has not been preconfigured, you will need to manually enter the details of the MMS account. This is a two-stage process: in the first stage you must set up the data connection, and in the second stage you must define the address of the MMS server on the Internet.

## Setting up a data connection

You will need the name of the MMS APN and any associated username or password. To avoid conflicts with other applications, select the **Secure WAP Network** setting when setting up the **Connect via** description.

## Defining the server

1. From the **Home** screen, select **Start > Messaging**.
2. Highlight the MMS entry, and select **Menu > Settings**.
3. Select **Menu > MMSC Settings**, and on the following page select **Menu > New**.
4. Enter a name for the server details in the **Name** field.  
Enter the following details:
  - MMSC URL** - enter the address of the server, as supplied by your Service Provider.
  - WAP gateway** - enter the WAP gateway to be used for this connection, as supplied by your Service Provider.
  - Port** - enter the port number.
  - Connect via** - point the MMS server towards the correct connection point. If you set up the MMS using the **Secure WAP network** setting, you must select the **Secure WAP network** setting here.
  - Max. sending size** - please contact your Service Provider to obtain this value.
5. Select **Done**.
6. Select your MMS entry and select **Menu > Set as Default**. A tick is displayed next to your chosen MMS entry.
7. Press the **Home** key to return to the **Home** screen. Your Toshiba phone is now configured for MMS.

# Messaging

## Pocket MSN

Pocket MSN on your Toshiba phone provides almost instant access to your MSN Hotmail inbox, your MSN Messenger contacts list, and options for customizing your Pocket MSN experience.

MSN Messenger is an instant messaging service hosted by MSN via the Internet. This service is currently free of charge.

Pocket MSN offers you:

- MSN Hotmail. Read, write, and send email, or manage your Hotmail folders.
- MSN Messenger. See who's online. Send and receive instant messages. Subscribe to status updates for selected contacts so you're notified when they're online.
- Options and settings you can use to create a custom Pocket MSN experience.
- To use it, select **Start > More > More > Pocket MSN**.



**NOTE:** You need to have either a Microsoft.NET Passport ([www.passport.com](http://www.passport.com)) or a Hotmail account ([www.hotmail.com](http://www.hotmail.com)) to use MSN Messenger. In addition, your Toshiba phone must be connected to the Internet.

To obtain a Passport, go to:  
<http://www.passport.com>.

To create a Hotmail account, go to:  
<http://www.hotmail.com>.

## About MSN Hotmail

MSN Hotmail provides you with access to your Hotmail inbox, on your Toshiba smartphone, even when you're mobile. You can read, send, and reply to emails, as well as manage your folders. You can also mark email attachments for downloading.





# Messaging

## MSN Messenger overview

With MSN Messenger you can send instant messages to your contacts' mobile device or PC.

To use MSN Messenger, you need Microsoft Passport Network credentials. After obtaining the credentials, complete the following tasks:

1. Set up a connection to the Internet with your Toshiba phone.
2. Set up an MSN Messenger account.
3. Sign in to MSN Messenger.

To access MSN Messenger:

1. From the **Home** screen, select **Start > More > More > Pocket MSN > MSN Messenger > Sign In**.
2. Enter the email address and password for your Microsoft Passport Network credentials or Hotmail account, and select **Sign in**.



**NOTE:** Signing in to an account may take several minutes, depending on your connection speed and how busy your mobile network is.

3. To sign out, select **Menu > Sign out**.

# Text Input

## Input methods

Your Toshiba phone has three text input methods:

- Multi-press
- XT9
- Numeric

Multi-press and XT9 modes are used for text, and Numeric mode is used for number entry.

## Method indicators

When you move the cursor into a field that requires you to enter text or numbers, it will auto-select an appropriate input method. The present mode indicator will display one of the following text input methods in the top right corner of the status bar:

- **abc** - Multi-press text mode, lower case.
- **ABC** - Multi-press mode, initial letter is upper case and subsequent letters are lower case.
- **ABC** - Multi-press text mode with caps lock.
- **123** - Numeric mode.
- **xt9** - XT9 input mode, lower case.
- **xT9** - XT9 input mode, initial letter upper case, subsequent letters lower case.

- **xT9** - XT9 input mode with caps lock.

## Multi-press mode

Your keypad has numbers **0** through **9**, plus the **\*** and **#** keys. Each number key also represents three or four letters. In Multi-press mode, enter a letter by repeatedly pressing the key that contains the letter you want until that letter is displayed.



**EXAMPLE:** To enter the letter **c**, press the **2** key three times quickly.

To select another character from the same key that you have just been using, you need to pause before starting to type again. To set the pause time period, select **Start > Settings > Accessibility > Multi-press Timeout**.

When in Multi-press mode, the mode indicator will show either **abc**, **Abc**, or **ABC** indicating lower case, initial capital letter, or upper case.

**TIP:** When using Multi-press mode, the first letter of a sentence is automatically capitalised.



# Text Input

## XT9 mode

This allows you to enter words with only one keystroke per letter. Every key has more than one letter assigned to it. For example, pressing the **3** key can enter the letters D, E or F. XT9 mode compares your preceding keystrokes with an internal dictionary to formulate the most likely word. As a result, entering text in XT9 mode requires far fewer keystrokes, and can be much quicker, than the conventional Multi-press mode.



**NOTE:** When using XT9 mode, other words appear in the window below. These are words that could be created using that sequence. Scroll down the list and select the appropriate word by pressing the **Action** key, if necessary.

## Numeric mode

Using Numeric mode, you press a key to enter the corresponding number into a field. Typically the input mode changes to Numeric mode for the entry of telephone numbers.

## To enter numbers in text

1. Press and hold the \* key to change to Numeric mode.
2. Enter numbers with the keypad.
3. Press the \* key again and hold to return to previous mode.



**TIP:** To enter numbers without changing to Numeric mode, press and hold the corresponding key for 1 second.

## More tips on text entry

- To switch between Upper case, Lower case and Caps Lock, press the \* key.
- To delete a single character, press the **Back/Delete** key briefly. To delete all the characters in the message area, press and hold the **Back/Delete** key.
- To enter a space or symbol in Multi-press or XT9 mode, press the # key briefly.
- To display miscellaneous symbols and characters, press and hold the # key.
- To enter the + character for international calls, press and hold the **0** key.





# Settings

## Customizing your Home screen

You can customize your **Home** screen using:

- A picture file (.bmp, .jpg or .gif).
- A pre-packaged file that includes a picture, a colour scheme and a new layout (.hme or .cab).



**TIP:** You can copy an image to your Toshiba phone from your PC using ActiveSync. For best results, use images with the same screen resolution as your phone's screen resolution - 240 x 320 pixels.

## Changing your Home screen

1. From the **Home** screen, select **Start > Settings > Home screen**.
2. Select your desired options, and select **Done**.



**NOTE:** Whilst selecting your desired options, select **More...** to access settings on the following page.

## An alternative method to set an image as the Home screen background

1. From the **Home** screen, select **Start > More > Pictures & Videos**.
2. Select the image to set as the background.
3. Select **Menu > Use as Home screen**.
4. Use the **Navigation** key to select the portion of the picture you want to use, and select **Next**.
5. In the **Adjust the transparency** field, select a higher percentage for a more transparent picture or a lower percentage for a more opaque picture.
6. Select **Finish**. Your selected image is set as your **Home** screen background.

## Sounds

You can set a different ringtone for different contacts. The ring tone can also be used for other events such as notifications or reminders when a calendar appointment is due.



**TIP:** You can copy sounds to your phone from your PC using ActiveSync. Sound files can be in either midi, wma, mp3, amr or wav file format. For notifications or reminders, use either midi, wma, mp3, amr or wav files.



# Settings

## Specifying the sound for an event

1. From the **Home** screen, select **Start > Settings > Sounds**.
2. Select a sound, in an event. Your Toshiba phone plays each sound as you select it. Select **None** if you don't want to hear the sound.
3. Repeat for each event, and select **Done**.

## Profiles

The Profile feature defines the Ring type, Ring volume, Alarm type and Alarm volume. Your Toshiba phone has several profiles, and you can customize these profiles as follows:

### Changing the current profile

The Profile feature defines how your Toshiba phone notifies you of certain functions, such as incoming calls and alarms.

To change your current profile:

1. From the **Home** screen, select the profile type. For example, **Profile: Normal**.
2. Select a new profile.

3. Select **Done**.



**NOTE:** Some profiles are automatically selected by your Toshiba phone depending on how the phone is being used at the time. For example, the device will move to **Headset** profile when you plug in a headset.



**TIP:** To change the profile using the Quick List, press the **Power** key to select the desired profile.



**NOTE:** The **Automatic** profile has special features, and adjusts according to various situations. If you select this profile your Toshiba phone will perform in **Normal** mode, most of the time. However, if you have set up a calendar appointment, for example, the **Meeting** profile is activated when the appointment takes place.

## Customizing a profile

1. From the **Home** screen, select the profile type. For example, **Profile Normal**.
2. Select **Menu > Edit**.



# Settings

3. Modify the settings, and select **Done**.  
To cancel without saving changes, select **Cancel**.



**NOTE:** To revert to the default profile settings, select **Menu > Reset to default**.

## Clock & alarm settings

### Setting the date and time

1. From the **Home** screen, select **Start > Settings > Clock & Alarm > Date and Time**.
2. Select your time zone in the **Time zone** field.
3. Edit the month, day, or year in the **Date** field.
4. Edit the hour, minute, and second in the **Time** field.
5. Select **Done**.



**NOTE:** These settings are only lost if you manually reset your Toshiba phone. Your settings are preserved if you power off the phone, or if the battery is fully discharged.

### Setting the alarm

1. From the **Home** screen, select **Start > Settings > Clock & Alarm > Alarm**.
2. Select whether or not to activate the alarm.
3. Enter the alarm time in the **Alarm time** field.
4. Select **Done**.

### Owner information

Entering owner information could allow someone to return your Toshiba phone to you if it becomes lost.

1. From the **Home** screen, select **Start > Settings > More... > Owner Information**.
2. Enter your name, alternative contact telephone number, e-mail address and any other necessary information in the fields provided.
3. Select **Done**.

### Changing accessibility settings

1. From the **Home** screen, select **Start > Settings > More... > Accessibility**.
2. Select your preference for the following:  
**System font size** - sets the size of the font displayed on the screen.



# Settings

**Multipress time out** - sets the length of time between keypresses when entering text in Multipress mode.

**Confirmation time out** - sets the delay before an unconfirmed action times out.

**In-call alert volume** - sets the volume of sounds played while you are in a call.

3. Select **Done**.

**NOTE:** The time format is dependent on the



time format setup in your phone settings, under **Regional Settings**.

## Changing regional settings

You can specify the language, locale, date and time, number and currency formatting options.

## Changing power management settings

Use Power Management to check the battery status and configure settings that prolong battery life.

1. From the **Home** screen, select **Start > Settings > Power Management**.

2. Adjust the following:

**Backlight time out on battery** - select the time period for the phone to be idle before the backlight turns off.

**Backlight time out on AC** - select the time period for the phone to be idle before the backlight turns off when using AC power.

**Display time out** - select the time period for the phone to be idle before the screen turns off.

3. Select **Done**.

## Security settings

It is advisable to apply certain security features in the event that your Toshiba phone is lost or stolen. In addition, some security features can be applied to prevent unauthorised use.

You can apply the following security:

- **Enable SIM PIN** - prevents unauthorised use of your SIM card in any phone.
- **Key lock** - prevents accidental calls and operations.
- **Device lock** - prevents unauthorised use.

# Settings

## Enabling your SIM PIN

Be sure to make a note of your personal identification number (PIN). When the SIM PIN is disabled, you must provide this PIN to enable the SIM. The PIN is provided with the SIM card.

To enable your PIN:

1. From the **Home** screen, select **Start > Settings > Security > Enable SIM PIN**.
2. Enter your current PIN and select **Done**.

## Disabling your SIM PIN

This option is available only if your SIM PIN has been enabled.

1. From the **Home** screen, select **Start > Settings > Security > Disable SIM PIN**.
2. Enter your current PIN, and select **Done**.



**WARNING:** If you fail to enter the correct PIN for your SIM card following three consecutive unsuccessful attempts, you will need to contact your Service Provider to obtain the Personal Unblock Key (PUK). Do not attempt to guess the PUK as it will render your SIM card permanently inoperative following ten consecutive unsuccessful attempts

## Changing your SIM PIN

This option is available only if your SIM PIN has been enabled.

1. From the **Home** screen, select **Start > Settings > Security > Change SIM PIN**.
2. Enter your current PIN and New PIN.
3. Select **Done**.

## Locking the keypad

Locking the keypad disables the keypad functionality. This is a helpful feature if, for example, your Toshiba phone is in your pocket and you want to prevent accidental keypresses.

To lock the keypad:

- From the **Home** screen, press and hold the **Home** key.
- Once the keypad is locked, the **Left Soft** key label changes to **Unlock**.



**NOTE:** You can still receive and make emergency calls, when the keypad is locked.



**TIP:** To lock the keypad using the Quick List, press and hold the **Power** key to select **Key lock**.





# Settings

## Unlocking the Keypad

Simply select **Unlock** from the **Home** screen. The correct key press required to unlock the keypad is displayed.

## Enabling the device lock

This security measure complements the SIM PIN feature to provide additional security to your Toshiba phone. It means that the phone is protected from unauthorised use.

To enable the device lock:

1. From the **Home** screen, select **Start > Settings > Security > Device Lock**.
2. To select an inactive time period, check the **Prompt if device unused for** box and select an inactive time period.
3. Enter and confirm your password.
4. Select **Done**.

## Disabling the device lock

1. From the **Home** screen, select **Start > Settings > Security > Device Lock**.
2. Enter your password.
3. Uncheck the **Prompt if device unused for** box.

4. Select **Done**.



**NOTE:** Please make a note of your password.



**TIP:** To lock the keypad using the Quick List, press and hold the **Power** key to select **Key lock**.

## Enabling Fingerprint

The Fingerprint feature helps provide additional security on your Toshiba phone, by protecting it from unauthorised use.

To enable the Fingerprint feature:

1. From the **Home** screen, select **Start > Settings > Security > Fingerprint**.
2. Select the finger you want to enrol from the list, and press the **Action** key.



**NOTE:** If the device lock is enabled, enter the password on the Device Lock screen, and select **Unlock**.

3. Swipe the finger three times to enrol it to the fingerprint sensor.
4. Click **OK**.

# Settings

## Disabling Fingerprint

1. From the **Home** screen, select **Start > Settings > Security > Fingerprint**.
2. Select **Delete** from the menu with focused finger list item.
3. Select **Yes**.

## Phone settings

### Setting call barring

Call barring allows you to screen incoming and outgoing calls.

To set call barring:

1. From the **Home** screen, select **Start > Settings > Phone > Call Barring**.
2. Choose the calls you want to block, and select **Done**.

### Setting call forwarding

1. From the **Home** screen, select **Start > Settings > Phone > Call Forwarding**.
2. Select one of the following settings:
  - Unconditional** - forwards all calls.
  - No Reply** - forwards calls when your line is not answered.

**Busy** - forwards calls when your line is busy.

**Unavailable** - forwards calls when your Toshiba phone is off or out of service range.

**Data Calls** - forwards all data calls.

**Fax Calls** - forwards all fax calls.

3. Enter the forwarding phone number.
4. Select **Done**.

### Setting call options

1. From the **Home** screen, select **Start > Settings > Phone > Call Options**.
2. Enter individual settings for the following:
  - Any key answer**
  - Show SIM contacts**
  - Voice mail number**
  - Text message service centre**
  - Country code**
  - Dialling code**
3. Select **Done**.



# Settings

## Setting call waiting

When you are in another call, the call waiting feature will notify you of an incoming call.

To set call waiting:

1. From the **Home** screen, select **Start > Settings > Phone > Call Waiting**.
2. Check or uncheck the **Provide call waiting notifications** box, using the **Action** key.
3. Select **Done**.

## Configuring Caller ID

Configuring Caller ID allows selected callers to view your name and phone number information on their phone when you call them.

To configure Caller ID:

1. From the **Home** screen, select **Start > Settings > Phone > Caller ID**.
2. Choose the callers, and select **Done**.

## Configuring channels

1. From the **Home** screen, select **Start > Settings > Phone > Channels**.
2. Choose the options you want, and select **Done**.

## Setting fixed dialling

You can restrict your Toshiba phone to dial only the phone number(s) or area code(s) that you specify in a Fixed Dialling list.

To set fixed dialling:

1. From the **Home** screen, select **Start > Settings > Phone > Fixed Dialling > Enable fixed dialling > Done**.
2. Select **Menu > Edit Numbers > Menu > Add**.
3. Enter the phone number or area code to restrict, in the **Number pattern** field.
4. Repeat steps 2 and 3 to add more numbers. Select **Done** when you are finished.
5. Enter PIN2 and select **Done**.

## Selecting a mode

1. From the **Home** screen, select **Start > Settings > Phone > Mode Selection**.
2. Choose one of the following:  
**Automatic** - selects network mode automatically.  
**HSDPA** - selects 3G network mode.  
**GSM** - selects 2G/2.5G network mode.
3. Select **Done**.



# Settings

## Selecting a network

1. From the **Home** screen, select **Start > Settings > Phone > Networks**.
2. Choose one of the following:  
**Manual** - selects a specific network.  
**Automatic** - selects more networks automatically.
3. Select **Menu** and choose one of the following:  
**Find a New Network**  
**Select a Network**  
**Preferred Networks**
4. Choose the network you want to use, and select **Done**.

## Removing Programs

This feature removes additionally installed software programs.

 **NOTE:** Programs that come with your Toshiba phone cannot be removed.

1. From the **Home** screen, select **Start > Settings > Remove Programs**.
2. Choose the program to remove.
3. Select **Menu > Remove**.

## Error Reporting

### Turning Error Reporting on/off

Error Reporting sends data from your Toshiba phone to technical support groups, who use the data to diagnose a program error for a device running Windows Mobile software. A text file is created whenever an error is detected, and can be delivered to support personnel if you choose to send it. If a program error occurs, Error Reporting starts automatically. The information Microsoft receives is used by programming groups at Microsoft. The data is used for quality control and will not be used for tracking individual users, installations or for any marketing purpose.

1. From the **Home** screen, select **Start > Settings > More... > Error Reporting**.
2. In the **Error Reporting** field, select either **Enable** or **Disable**.
3. Select **Done**.

# Settings

## Video call settings

To set the video call settings

1. From the **Home** screen, select **Start > Settings > More... > Video Call Settings**.
2. Choose individual settings from the following:  
**Ring Tone** - choose your ring tone for incoming video calls.  
**Display Picture** - select an icon or a custom image to send whilst holding call, or block sending video.  
**Call Forwarding** - forwards the video call.
3. Select **Done**.

## SIMLock settings

To activate the SIM Lock

1. From the **Home** screen, select **Start > Settings > More... > SIMLock**.
2. Check the **Prompt if SIM unused for** box.
3. Enter and confirm a password with 8 digits.
4. Select **Done**.

 **NOTE:** Please make a note of your password.

 **NOTE:** If you activate the SIMLock, you will only be able to use the SIM card used when you activated SIMLock in your Toshiba phone.

 **NOTE:** To disable this feature, enter your 8 digit password and uncheck the **Prompt if SIM unused for** box.

## Viewing the About details

### Confirming the installed software version

1. From the **Home** screen, select **Start > Settings > More... > About**.
2. View the installed software details by scrolling down the screen.
3. Select **Done**.



# Connectivity

## Automatic set up of your data connections

Your Toshiba phone is able to configure itself for data services for many of the major Operators. Insert your SIM card and switch on your phone.

You can find the shortcuts for the provisioning files in the Start menu of your Toshiba phone. They can be installed easily as follows:

1. Select **Start > More > More**. You find the required directory as the final icon.
2. Open the directory and select the icon for the network that you would like to use.
3. After approximately five to ten seconds, a message will be displayed in your Inbox informing you that your device settings have been changed. You now have the appropriate WAP, Proxy and MMSC settings installed.

The use of Web, WAP and MMS services is subject to your Service Provider. You must ensure that your subscription has Web, WAP and MMS enabled.

## Manual set up of your data connections



**NOTE:** If you connect to the Internet using your Service Provider's data network, the service may be provided through a GPRS connection (fast, but generally billed by volume of data transferred), or through a Circuit Switched connection (slow, but generally billed by amount of time connected). You should check with your Service Provider which connection you will use on their network.

## Creating a GPRS connection

GPRS is a packet-based wireless communication service which allows users to send and receive data, with their mobile phones, in functions such as e-mail and web-browsing. Normally, your Service Providers will charge for this service based on the data traffic volume. But, every network connection is different. You should gather all the relevant data you need from your Service Provider.





# Connectivity

To create a GPRS connection:

1. From the **Home** screen, select **Start > Settings > Connections > GPRS > Menu > Add**.
2. Enter the following information:  
**Description** - enter a name for the connection.  
**Connects to** - select the type of network to which you will connect.  
**Access point** - enter the access point name.  
**User name** - enter your user name for the GPRS network, if required.  
**Password** - enter your password, if required.  
**Primary DNS** - enter the primary Domain Name System (DNS) address, if required.  
**Secondary DNS** - enter the secondary DNS address, if required.  
**IP address** - enter the Internet Protocol (IP) address for the device, if required.
3. Select **Done**.

Your Toshiba phone uses this connection when you connect to the Internet.

## Creating a dial-up connection



**NOTE:** Every network connection is different. You should gather all the relevant information you need for this service from your Service Provider.

1. From the **Home** screen, select **Start > Settings > Connections > Dial-up > Menu > Add**.
2. Enter the following information:  
**Description** - enter a name for the connection.  
**Connects to** - select the type of network to which you will connect.  
**Phone number** - enter the phone number used to dial the network.  
**User name** - enter your network user name, if required.  
**Password** - enter your password, if required.  
**Domain** - enter the domain name, if required.
3. Select **Done**.

# Connectivity

## Creating a proxy connection

Depending on your Service Provider's configuration, you may need to add a proxy connection to allow your Toshiba phone to access the Internet or WAP services. Every network connection is different and your Service Provider will be able to advise if you need to create a proxy connection. You should gather all the relevant information you need, from your Service Provider, before creating a proxy connection.

To create a proxy connection:

1. From the **Home** screen, select **Start > Settings > Connections > Proxy > Menu > Add**.

2. Enter the following information:

**Description** - enter a name for the connection.

**Connects from** - enter the type of network from which you will connect.

**Connects to** - select the type of network to which you will connect.

**Proxy [name:port]** - enter the proxy server name and port number.

**Type** - select the type of proxy connection to create.

**User name** - enter your user name for the

GPRS network, if required.

**Password** - enter your password, if required.

3. Select **Done**.

## Creating a VPN connection

**IMPORTANT:** Please ensure that you have set up a successful GPRS connection before trying to create a VPN connection - the VPN connection uses the GPRS connection to connect to your Work network. You should gather all the relevant information you need before creating a VPN connection. For the VPN connection to work, you must also refer to the **Connecting to intranet URLs** section below.

1. From the **Home** screen, select **Start > Settings > Connections > VPN > Menu > Add**.

2. Enter the following information

**Description** - enter a name for the connection.

**VPN type** - select the VPN type.

**Server** - enter the VPN server name.

**Connects from** - enter the type of network from which you will connect to the VPN (typically **The Internet**).

**Connects to** - select the type of network to which you will connect (typically **Work**).





# Connectivity

**User name** - enter your user name for the VPN.

**Password** - enter your password, if required.

**Domain** - enter the domain name, if required.

If you selected **IPSec** in **VPN type**, in **IPSec authentication**, select the type of authentication: **Pre-Shared Key** or **Certificate**.

3. Select **Done**.

## Connecting to intranet URLs

1. From the **Home** screen, select **Start > Settings > Connections > Menu > Advanced > Menu > Work URL Exceptions > Menu > Add**.
2. Enter the URL in the **URL Pattern** field.
3. Select **Done**. Separate multiple URLs with a semicolon.

## Using a specific connection to connect to the chosen networks

You must define a specific connection to the chosen networks, to connect your Toshiba phone to the correct access point for a particular data transfer type.

To use a specific connection to connect to chosen networks:

1. From the **Home** screen, select **Start > Settings > Connections > Menu > Advanced**.
2. In **Internet** connection, Select the connection you want to use for general Web access in the **Internet** connection field.
3. Select **Done**.



**NOTE:** Similarly, select the connection you wish to use for the WAP network.



**NOTE:** The **Work connection** is used if you are planning to use a Virtual Private Network connection.

# Connectivity

## Bluetooth

Bluetooth has three modes: **Off**, **On** and **Visible**. When Bluetooth is set to **On**, your Toshiba phone will be connected to the devices it is already paired with, but will not be visible to new devices. In **Visible** mode your Toshiba phone will perform in the **On** state, but it will also be visible to new devices within range, and you will also be able to receive data from other devices.

### Turning Bluetooth on and off

By default Bluetooth is turned off. If you turn it on, and then turn your Toshiba phone off, Bluetooth will also be turned off. But when you turn on your phone again, Bluetooth will turn on automatically.

To turn Bluetooth on/off:

1. From the **Home** screen, select **Start > Settings > Connections > Bluetooth**.
2. Check the **Turn on Bluetooth** box to activate Bluetooth. Uncheck to deactivate.
3. Check the **Make this device visible to other devices** box if you want your phone to be visible to other devices within range.

## Creating a Bluetooth partnership

Before creating a Bluetooth partnership:

- Ensure that your Toshiba phone and the device you are connecting to are within close range.
- Your Toshiba phone has Bluetooth turned **On** and that the device you are connecting to is in **Visible** mode.

To create a bluetooth partnership:

1. From the **Home** screen, select **Start > Settings > Connections > Bluetooth > Menu > Devices > Menu > Add new device**. Your Toshiba phone searches for other Bluetooth-enabled devices and displays them in the list.
2. Select the device and select **Next**.
3. In **Passcode**, if you want to use a passcode (recommended for enhanced security), enter an alphanumeric passcode, between 1 and 16 characters in length, and select **Next**. Alternatively, leave the passcode blank, and select **Next**.
4. Enter the same passcode on the partnering device and respond to any prompts.





# Connectivity

## Ending a Bluetooth partnership

1. From the **Home** screen, select **Start > Settings > Connections > Bluetooth > Menu > Devices**.
2. Select the Bluetooth partnership you want to end.
3. Select **Menu > Delete**.

## Making your Toshiba phone visible to other Bluetooth devices

Your Toshiba phone must be set to **Visible** to:

- Receive data
- Allow other Bluetooth devices to detect your Toshiba phone.
- Offer services to other devices, such as Internet Sharing.

To make your Toshiba phone visible to other devices:

1. From the **Home** screen, select **Start > Settings > Connections > Bluetooth**.
2. Check the **Make this device visible to other devices** box.
3. Select **Done**.

Other Bluetooth-enabled devices can now detect your Toshiba phone.

## Accepting a Bluetooth partnership

1. Ensure that Bluetooth is turned on and that your Toshiba phone is visible to other Bluetooth-enabled devices.
2. When prompted to accept a Bluetooth partnership with another device, select **Yes**.
3. If you want to use a passcode (recommended for enhanced security), enter an alphanumeric passcode, between 1 and 16 characters in length in the **Passcode** field, and select **Next**.
4. Enter the same passcode on the partnering device and respond to any prompts. The Bluetooth partnership is created. You can now exchange data with the other device.



# Connectivity

## Setting up an incoming Bluetooth COM port

Some programs can only establish a connection through a serial (COM) port, even if the device itself is Bluetooth-enabled. To make it possible for such programs to use a Bluetooth connection, you must set up a virtual COM port. Once created, this virtual port can be used like any other COM port. You can use a virtual COM port for programs that, for example, connect to a GPS receiver, or to connect to a Bluetooth-enabled printer.

To set up an incoming Bluetooth COM port:

1. Ensure that your Toshiba phone is currently connected to the other device via Bluetooth.
2. From the **Home** screen, select **Start > Settings > Connections > Bluetooth > Menu > COM Ports > Menu > New Incoming Port**.
3. Select a numbered COM port from the list.
4. To use this COM port to communicate only with devices with which your Toshiba phone has a Bluetooth partnership, check the **Secure Connection** box.
5. Select **Done**.

## Setting up an outgoing Bluetooth COM port

The New Outgoing Port menu command is available only if one or more Bluetooth-connected devices support serial (COM) connections.

1. Ensure that your Toshiba phone is currently connected to the other device via Bluetooth.
2. From the **Home** screen, select **Start > Settings > Connections > Bluetooth > Menu > COM Ports > Menu > New Outgoing Port**.
3. Select a numbered COM port from the list.
4. To use this COM port to communicate only with devices with which your Toshiba phone has a Bluetooth partnership, check the **Secure Connection** box.
5. Select **Done**.





# Connectivity

## Beams

The term 'beam' is used to describe the short range transfer of data between two devices via a Bluetooth connection.

### Beaming an item

To beam Calendar, Contacts, Tasks, and Pictures & Videos files and data to other devices:

1. Select the item you want to beam, such as an appointment in Calendar, a task in Tasks, a contact in Contacts, or a picture in Pictures & Videos.
2. Select **Menu > Beam Appointment**. If you are beaming a contact, select **Menu > Send Contact > Beam**.
3. Select the device to which you want to send the data.
4. Select **Beam**.

### Configuring your Toshiba phone to receive beamed data

1. From the **Home** screen, select **Start > Settings > Connections > Beam > Receive incoming beams**.
2. Select **Done**.

### Receiving beamed data

For security reasons, your Toshiba phone is set by default not to receive beamed data.

To receive beamed data:

1. Ensure the **Make this device visible to other devices** setting is enabled, and that your Toshiba phone is within range of the device beaming the data.
2. You are notified when data is being received on your Toshiba phone.
3. Once the data has transferred, select **Yes** to save, or **No** to discard.

# Connectivity

## Checking for a Wireless LAN signal

Before you start a Wi-Fi connection, you must verify that your Toshiba phone has access to a Wireless LAN channel signal. You can check the current wireless connection status from the following three screens on your phone.

- **Today** screen - If your Toshiba phone detects a Wireless LAN network connection, the Wireless LAN connection icon is displayed at the top of the **Today** screen.
- **Wireless Manager** screen - The current connection status and signal quality for each specific wireless channel is displayed on the **Wireless Manager** screen with the current configuration.
- **Wi-Fi** screen - Displays the wireless networks currently available and allows you to add new ones if available.

**NOTE:** Wireless LAN (Wi-Fi) is the default wireless channel setting for your Toshiba phone. However, GPRS starts by default if your phone does not detect a Wi-Fi signal.



## Connecting to a Wi-Fi network

1. Select **Start > Settings > Connections > Wireless Manager**. You can see the current Wi-Fi status displayed in this screen.
2. Highlight **Wi-Fi**, and then select **Menu > Wi-Fi Settings** to configure wireless networks.
3. When the networks are detected, select a network from the list displayed.

## Wireless Manager

The Wireless Manager allows you to easily switch the Bluetooth and Telephony functionality on/off.

To start the Wireless Manager, either:

- Press the **Power** key, and select **Wireless Manager** from the Quick List, or
- From the **Home** screen, select **Start > Settings > Connections > Wireless Manager**.

Active items are coloured white. Inactive items are displayed with a cross.





# Connectivity

## Turning the telephony element on/off

Switch the telephony radio transmission element of your Toshiba phone off by selecting the Phone icon. Alternatively, press the **4** key. When a cross is displayed next to the receiver icon, your phone is in 'flight mode' for the telephony element. You will not be able to make/receive telephone calls or use your data network. You can still use Bluetooth however, if activated.

To turn the telephony element back on, select the option again, or press the **4** key again.

## Disconnecting the current active data connection

You can disconnect the data connection without switching off the telephone by selecting **Menu > Disconnect Cellular Data**.

The data connection will automatically reconnect if you are using the Direct Push email solution. For this to work your Toshiba phone must have a connection permanently open to receive emails from the email server. If you wish to disconnect the data connection in this scenario, you must first disable the Direct Push email.

To disable the Direct Push email:

1. From the **Home** screen, select **Start > ActiveSync > Menu > Schedule**.
2. Change the **Peak times** and **Off-peak times** settings to **Manually**.

To enable the Direct Push email again, return to the ActiveSync **Schedule** page and select **As items arrive**.

## Enabling and disabling all wireless elements

To switch both the Bluetooth and Telephony on/off at the same time, select **All** or press the **1** key.

## Wireless LAN and Bluetooth interference

Because Wireless LAN and Bluetooth equipment both operate within the same frequency band (2.4GHz), if you are using Wireless LAN on your Toshiba phone near a device using Bluetooth, Wireless LAN and Bluetooth interference can occur. This causes a lowered transmit rate, noise, and an unstable connection. This can also occur if you are using Bluetooth on your Toshiba phone near a device using Wireless LAN.

# Connectivity

To stop the interference occurring, you need to do the following:

- When using Bluetooth on your Toshiba phone, keep the phone and other Bluetooth devices at a distance of at least 10m from any devices using Wireless LAN.
- When you are unable to keep at a distance of 10m from any device/s using Wireless LAN and need to use Bluetooth on your Toshiba phone, please power off the device/s using Wireless LAN.

## USB to PC

### Setting the USB to PC

1. From the **Home** screen, select **Start > Settings > Connections**.
2. Select **USB to PC**.
3. Select the relevant box to enable advanced network functionality.
4. Select **Done**.



# Applications & Multimedia

Your Toshiba phone is installed with the following applications:

- Internet Explorer
- Tasks
- Windows Media
- Calendar
- Messaging
- Contacts
- ActiveSync
- Call History
- Settings
- Games
- Voice Notes
- Pictures & Videos
- Accessories
- Internet Sharing
- File Explorer
- FingerLaunch
- GoldKey
- Java
- Opera Browser
- Picstel Viewer

- Pocket MSN
- SIM Manager
- Speed Dial
- Teleport
- TIPTalk
- Zoom

## Internet Explorer

### Open Internet Explorer

From the **Home** screen, select **Start > Internet Explorer**.

### Go to a link

1. From the **Home** screen, select **Start > Internet Explorer**.
2. Scroll up or down to view all available links.
3. Select the link.

### Go to a web page

1. From the **Home** screen, select **Start > Internet Explorer > Menu > Address Bar**.
2. Enter the address.
3. Select **Go**.



# Applications & Multimedia

## Changing the text size on web pages

1. While on a web page, select **Menu > Zoom**.
2. Select the size you want.

## Accessing a web page from history

1. While on a web page, select **Menu > History**.
2. Select the web page, and select **Go**.

## Showing or hiding web page pictures

While on a web page, select **Menu > View > Show Pictures**.

## Viewing a favorite

1. While on a web page, select **Menu > Favourites**.
2. Select a favourite, and select **Go**.

## Clearing history, cookies, or temporary files

Following frequent use of the Internet, your Toshiba phone may accumulate data that uses up the storage capacity. It is advisable to delete certain files to free up the storage on your phone.

To clear history, cookies or temporary files:

1. While on a web page, select **Menu > Tools > Options > Memory**.
2. Select the memory type to clear.
3. Select **Clear > Yes > Done**.

## Sending a link via email

1. Go to the web page you want to send.
2. Select **Menu > Tools > Send Link via Email**.
3. Select **Text Message** or **Outlook Email**. A new message is created with the page address inserted in the message body.

## Tasks

You can set a one-off task or a recurring task. You can also set reminders for your tasks.

## Creating a task

1. From the **Home** screen, select **Start > Tasks**.
2. Enter the task in the **Enter new task here** field.

# Applications & Multimedia

3. Press the **Action** key. A new task item is displayed.



**NOTE:** You can synchronize information on your Toshiba phone with your PC. This will keep your task list up to date in both locations.



**NOTE:** If you create a new task with a reminder on your PC and then synchronize tasks with your Toshiba phone, the reminder is activated at the time it was set on your PC.

## Deleting a task

1. From the **Home** screen, select **Start > Tasks**.
2. Select the task, and select **Menu > Delete Task**.

## Marking a task as complete

1. From the **Home** screen, select **Start > Tasks**.
2. Select the task, and select **Complete**.

## Changing a completed task to incomplete

1. From the **Home** screen, select **Start > Tasks**.
2. Select the task, and select **Activate**.

## Locating a task

1. From the **Home** screen, select **Start > Tasks**.
2. In the task list, do one of the following:
  - To sort the list, select **Menu > Sort By**, and select a sort option.
  - To filter the list by category, select **Menu > Filter**, and select the category you want displayed.



**NOTE:** Categories only appear in tasks that are synchronized with your PC.



**NOTE:** To filter your task further, select **Active Tasks** or **Completed Tasks**.





# Applications & Multimedia

## Windows Media

### Overview of Windows Media Player Mobile

You can use **Windows Media 10 Mobile for Smartphone** to play digital audio and video files that are stored on your Toshiba phone or on the Web.

The Windows Media Player Mobile can play the following types of files by default:

- Windows Media Audio (WMA)
- Windows Media Video (WMV)
- Motion Picture Experts Group-2 Audio Layer-3 (MP3).

This includes the following file extensions:

- .asf
- .wma
- .wmv
- .mp3.

Your Toshiba phone can also play back H.263 (.3gp) and .mp4 files.

In addition to Windows Mobile-based Smartphones, Windows Media player is available on other operating systems, including Windows Mobile-

based Pocket PCs and desktop computers running the Windows or Macintosh operating systems.

### Overview of the controls

By default, the following keys are assigned to Windows Media Player Mobile functions:

- **Action** key - plays or pauses a file.
- **Left Navigation** key - skips to a previous file.
- **Right Navigation** key - skips to the next file.
- **Up Navigation** key - increases the volume.
- **Down Navigation** key - decreases the volume.
- **#** key - turns the sound on or off.
- **0** key - switches to full screen during video playback.
- **\*** key - changes the star rating of the file.
- **Right Navigation** key (hold) - fast-forward a file.
- **Left Navigation** key (hold) - rewind a file.

# Applications & Multimedia

## Overview of screens and menus

Windows Media Player Mobile has three primary screens:

- **Playback** screen - displays the playback controls (such as Play, Pause, Next, Previous, and Volume), the star rating of the current file, the album art window, and the video window. You can change the appearance of this screen by selecting a different skin.
- **Now Playing** screen - displays the **Now Playing** playlist, which indicates the file currently playing as well as any files in the queue.
- **Library** screen - enables quick access of audio files, video files, and playlists. It contains categories such as My Music, My Video, My TV, and My Playlists. It also includes a link that lets you switch to the **Now Playing** screen.

Selecting the **Menu** option displays different options depending on the screen you are in.

## Now Playing screen settings

- **Library** - displays the library.
- **Move Up** - moves the selected item up in the playlist order.

- **Move Down** - moves the selected item down in the playlist order.
- **Delete from Playlist** - removes the selected item from the playlist.
- **Shuffle/Repeat > Shuffle** - plays the item in the **Now Playing** playlist in a random order.
- **Shuffle/Repeat > Repeat** - plays the item in the **Now Playing** playlist repeatedly.
- **Save Playlist** - saves the playlist.
- **Clear Now Playing** - removes all items from the **Now Playing** playlist.
- **Error Details** - displays error information about the selected item. An exclamation mark is displayed before the item name if error details are available.
- **Properties** - displays information about the selected file.

## Library screen settings

- **Queue Up** - adds the selected item to the end of the current playlist.
- **Delete from Library** - deletes the selected item from the library.



# Applications & Multimedia

- **Now Playing** - displays the **Now Playing** playlist.
- **Library > library name** - switches between libraries, for example between the **My Device** and **Storage Card** libraries.
- **Update Library** - adds new items to the library by searching your Toshiba phone or storage card.
- **Open File** - allows easy access of files that are not in the library.
- **Open URL** - allows you to play a file on a network, such as the Internet.
- **Properties** - displays information about the selected file.
- **Player** - switches to the player screen.

## Overview of licenses and protected files

Protected files are digital media files that are secured with a license to prevent unauthorized distribution or playback.

The license specifies how you can use the file. For example, a license can specify whether you can use the desktop player to synchronize a file to your Toshiba phone or it can specify how many times you

can play a file on your Toshiba phone. The terms of the license are specified by the person or company that provided the file.

Licenses are created and managed by a technology called Digital Rights Management (DRM). Because Windows Media player 10.1 Mobile for Smartphone supports Windows Media DRM 10, you can download and play protected files that you have obtained from compatible online stores, such as MSN Music. If permitted by the license and your Toshiba phone, you can play subscription or rental content from some online stores.

For information about compatible online stores and devices, access the PlaysForSure website at: [www.playsforsure.com](http://www.playsforsure.com).

When copying a protected file from your computer to your Toshiba phone:

- Always use the desktop version of Windows Media Player 10 to synchronize the file to your phone.
- Always synchronize the file to a storage card on your phone. Do not synchronize to a storage card that is inserted into a storage card reader.



**NOTE:** View the file properties to determine whether a file is protected.

# Applications & Multimedia

## Playing items on your Toshiba phone

Use the library to find and play songs, videos, and playlists that are stored on your Toshiba phone or storage card.

1. From the **Home** screen, select **Start > Windows Media > Menu > Library**.  
If necessary, from the **Library** screen, select **Menu > Library**, and select the library that you want to use, for example **Storage Card**.
2. Select a category (for example, **My Music** or **My Playlists**), and select the item that you want to play (such as a song, album, or artist name).
3. Select **Play**.



**NOTE:** To play a file stored on your Toshiba phone but not in a library, select **Menu > Open File**, from the **Library** screen. Select the item that you want to play (such as a file or a folder), and select **Play**.

## Playing items on a network

Use the **Open URL** setting to play a song or video that is stored on the Internet or on a network server.

1. If you are not in the **Library** screen, select **Menu > Library**.
2. Select **Menu > Open URL**.

3. In the **URL** box, enter a network address.  
or  
Select a URL that you have previously used in the **History** box.



**NOTE:** To play an item on a network, your Toshiba phone must be connected to a network. For more information about connecting your phone to a network, refer to the **Connectivity** section.

## Copying files to your Toshiba phone

You can either copy files to your Toshiba phone manually or you can automatically synchronize files between your PC and your Toshiba phone.

Use the Sync feature in the desktop version of Windows Media Player 10 to synchronize digital media files from your computer to your phone. Using Sync ensures that protected files and album art are copied to your phone correctly.



**NOTE:** To perform this function, you must have ActiveSync set up.



# Applications & Multimedia

## Changing the Player appearance

You can change the appearance of the Playback screen by choosing a new skin.

1. From the **Home** screen, select **Start > Windows Media > Menu > Options > Skins**.
2. Press the **Right** or **Left Navigation** key to view the skins. Select the skin you want.
3. Select **Done**.

**NOTE:** To download new skins, access the



WMplugins.com website at:  
[www.wmplugins.com](http://www.wmplugins.com).

After downloading a skin to your computer, use ActiveSync to copy the .skn and .bmp files to your Toshiba phone. To ensure that the skin is displayed on the **Skins** tab, do not store skin files in the Windows folder on your Toshiba phone.

## Troubleshooting

If you encounter any difficulty while using Windows Media Player Mobile, a number of resources are available on the web to help you resolve the issue. For more information, see the Troubleshooting Windows Media Player Mobile page on the Microsoft website at:

<http://go.microsoft.com/fwlink/?LinkId=29195> .

## Calendar

The Calendar application works like an electronic diary, allowing you to organize your events. Your entries can then be displayed as reminders on your Toshiba phone. Also, if you also use Outlook on your PC, you can synchronize the information between your PC and your phone.

## Scheduling an appointment

1. From the **Home** screen, select **Start > Calendar > Menu > New Appointment**.
2. Enter information about the appointment.
3. Select **Done**.

**NOTE:** All day events do not occupy blocks of time in the Calendar - instead they are displayed as banners at the top of the calendar.



## Making a recurring appointment

1. From the **Home** screen, select **Start > Calendar**.
2. Select the appointment.
3. Select **Edit**.



# Applications & Multimedia

4. Scroll down to the **Occurs** field and select one of the recurrence options.
5. Select **Done**.

## Updating an appointment

1. From the **Home** screen, select **Start > Calendar**.
2. Select the appointment.
3. Select **Edit**.
4. If the appointment is recurring, select **Yes** to edit only the current occurrence, or select **No** to edit the series.
5. Make your changes, and select **Done**.

## Deleting an appointment

1. From the **Home** screen, select **Start > Calendar**.
2. Select the appointment to delete in **Agenda** view.
3. Select **Menu > Delete Appointment**.
4. If the appointment is recurring, select **Yes** to delete the series, or select **No** to delete only the current occurrence.



**NOTE:** When you delete a Calendar appointment on your Toshiba phone, it is also deleted on your PC the next time you synchronize. But if the appointment has not been synchronized with a PC, it will only be deleted from your phone.



**TIP:** To cancel a deletion, select **Back**.

## Changing the work week display

1. From the **Home** screen, select **Start > Calendar > Menu > Options** and do one of the following:  
To specify the first day of the week, in the **First day of week** field, select **Sunday** or **Monday**.  
To specify the number of days you want displayed in a week, in the **Week view** field, select **5-day week**, **6-day week** or **7-day week**.
2. Select **Done**.



# Applications & Multimedia

## Changing the reminder time

By default, the reminder time is set to 15 minutes prior to an appointment.

1. From the **Home** screen, select **Start > Calendar > Menu > Options**.
2. Scroll to **Set reminders** and change the time.
3. Select **Done**.

## Viewing today's agenda

1. From the **Home** screen, select **Start > Calendar > Menu > Go to Today**.
2. From **Week** or **Month** view, select **Menu > Agenda View**.

 **TIP:** To view previous or approaching dates, scroll left or right, or select **Menu > Go to Date**.

## Viewing your agenda for a specific date

1. From the **Home** screen, select **Start > Calendar > Menu > Go to Date**.
2. Enter the date, and select **Done**.

## Viewing your schedule for the month

From the **Home** screen, select **Start > Calendar > Menu > Month View**.

## Messaging

For more information, please refer to the **Messaging** section.

## Contacts

You can customize each contact by adding a picture or a ring tone to uniquely identify the person who is calling you.

## Creating a new contact

1. From the **Home** screen, select **Start > Contacts > New**.
2. Enter the information for the new contact.
3. Select **Done**.

 **TIP:** If someone who isn't in your list of contacts, calls you or sends you a message, you can create a contact for that person from Call History or from the message by selecting **Menu > Save to Contacts**.

# Applications & Multimedia

## Creating a SIM contact

Contacts can be created and stored on a subscriber identity module (SIM.) If you move the SIM to another phone, your SIM contacts are moved as well.

1. From the **Home** screen, select **Start > Contacts > Menu > New SIM Contact**.
2. Enter the contact's information.
3. Select **Done**.



**TIP:** To save an existing contact to your SIM, select the contact and select **Menu > Save to SIM**.

## Viewing and editing a contact

1. From the **Home** screen, select **Start > Contacts**.
2. Select the contact.
3. To edit the contact, select **Menu > Edit**.
4. Select **Done**.

## Deleting a contact

1. From the **Home** screen, select **Start > Contacts**.
2. Scroll to the contact.

3. Select **Menu > Delete Contact**.

## Adding a picture to a contact

1. From the **Home** screen, select **Start > Contacts**.
2. Select the contact.
3. Select **Menu > Edit > Picture**.
4. Either select the picture you want to add, or select **Camera** and take a picture.
5. Select **Done**.

## Removing a picture from a contact

1. From the **Home** screen, select **Start > Contacts**.
2. Select the contact.
3. Select **Menu > Edit > Menu > Remove Picture**.
4. Select **Yes** on the Confirm screen.

## Assigning a ring tone to a contact

To easily identify who is calling you by the ring tone, you can assign a custom ring tone to each contact.

1. From the **Home** screen, select **Start > Contacts**.
2. Select the contact.





# Applications & Multimedia

3. Select **Menu > Edit > Custom ring tone** and select the ring tone you want.
4. Select **Done**.

## Sending contact information

Using a text message, you can quickly send someone information about a contact in your contact list.

To send contact information:

1. From the **Home** screen, select **Start > Contacts**.
2. Select the contact.
3. Select **Menu > Send Contact > Text Message**.
4. Select the contact information that you want to send and select **Done**.
5. In the new text message, enter the phone number of the person to whom you are sending the contact information and select **Send**.

## Assigning a category to a contact

You can use categories to help organize your contacts.

To assign a category to a contact:

1. From the **Home** screen, select **Start > Contacts**.

2. Select the contact.
3. Select **Menu > Edit > Categories**.
4. Select the category.
5. Select **Done**.



**NOTE:** Categories are shared between your appointments, contacts, and tasks. A category will remain in the list of shared categories as long as it is assigned to at least one appointment, contact, or task.

## ActiveSync

For more information, please refer to the **Other applications** section.

## Call History

For more information, please refer to the **Call Functions** section.

## Settings

For more information please refer to the **Settings** section.



# Applications & Multimedia

## Games

To access the game son your Toshiba phone:

1. From the **Home** screen, select **Start > More > Games**.
2. Select the game to play.

## Voice Notes

### Creating a voice recording

From the **Home** screen, select **Start > More > Voice Notes > Record** and start the recording.



**NOTE:** The recording data is stored in the phone memory automatically.

### Playing a voice recording

1. From the **Home** screen, select **Start > More > Voice Notes**.
2. Select the item to play in the **All Notes** screen and press the **Action** key.

## All Notes menu items

From the **Home** screen, select **Start > More > Voice Notes > Menu**. The following options are displayed:

- **Play** - plays the selected voice recording.
- **Record** - starts the recording.
- **Rename** - allows you to edit the title of the selected voice recording.
- **Delete** - removes the selected voice recording.
- **Set As Ringtone** - sets the selected voice recording as your ringtone.

## Pictures & Videos

Your Toshiba phone is equipped with a digital camera which can be used to capture photos and video clips.

### Capturing a photograph

You can launch the camera application in the following ways:

- Select **Start > More > Picture & Videos > Camera**.  
or



# Applications & Multimedia

- Press the **Camera** key on the side of your Toshiba phone.

## Taking a picture

Aim the camera at the subject and either:

- Select the **Left Softkey**.  
or
- Press the **Camera** key on the side of your Toshiba phone.

## Camera settings

- **Capt. Mode** - sets the camera mode. Select from:  
**Photo** - select from **Single**, **Timer** and **Burst**.  
**Video** - record videos.



**NOTE:** The **Burst** setting allows you to take multiple rapid-fire shots with one touch of the **Left Softkey** or **Camera** key. This is a very useful feature when shooting subjects in motion.

- **Pic. & Videos** - launches the **Pictures & Videos** feature, where you can review the images you have captured.

- **Zoom** - selects different zoom levels. The zoom level depends on the size of the picture being taken.
- **Landscape** - captures photos or videos in a wide-angle view, in a way that the longer side runs from side to side.
- **Portrait** - captures photos or videos in a way that the longer side runs from top to bottom.
- **Front Camera** - takes photos or videos with the camera lens facing you.
- **Rear Camera** - takes photos or videos with the outside camera lens.
- **Environment** - sets the colour correction of the camera to show the best effect at the current light. You may also choose to manually set up the correction.
- **Effect** - select the photo effect, such as **None**, **Greyscale**, **Sepia**, **Cool** or **Warm**.
- **Settings** - sets the resolution for the picture to be captured, the shutter sound, the store position and the mobile light setting.
- **About** - provides information about the camera.
- **Exit** - exits the **Camera** application.



# Applications & Multimedia

## Capturing a video

Your Toshiba phone can also capture videos that you can play back with Windows Media Player Mobile.

## Starting the video recorder

1. Press the **Camera** key on the side of your Toshiba phone.
2. Select the **Right Softkey > Mode > Video > Left Softkey**.
3. Press the **Left Softkey** to stop the recording.



**IMPORTANT:** Before taking the video, ensure that you have adequate free memory to store your video.

## Storing pictures and videos

All pictures and video files taken with your Toshiba phone are saved on the phone memory by default. But, you can set your phone to save pictures and video files to your miniSD card.

To store pictures and videos on your miniSD card:

1. Ensure that a miniSD card has been inserted into your Toshiba phone (refer to the **Getting started** section for installation instructions).

2. From within the **Camera** application, select **Menu > Settings > General**.
3. Select either **Device** or **Storage Card** in the **Save to** field.

## Precautions when using the camera

- Fingerprints or grease sticking to the lens may result in problems such as picture blurring. You should wipe the lens clean with a lens tissue.
- Try to maintain a steady hand when capturing pictures. Any movement of your Toshiba phone may lead to picture blurring.
- Avoid aiming the camera at bright light sources as this will affect the quality of the picture.
- Please consider the privacy of others when capturing pictures with your Toshiba phone.

## Viewing pictures and videos

You can view pictures and videos stored on your Toshiba phone or miniSD card using the **Pictures & Videos** application.

You can also set a picture to be your **Home** screen background, or you can send an image to a contact. To view pictures and videos, from the **Home** screen, select **Start > More > Pictures & Videos**.



# Applications & Multimedia

Use the **Navigation** key to preview the pictures.

## Pictures & Videos functions

From within the **Pictures & Videos** application, select **Menu** to view the available options:

- **Send** - sends pictures to contacts via MMS or email.
- **Beam** - transfers pictures to contacts via Bluetooth.
- **Save to Contact** - sets a picture as an icon representing a specified contact, shown within the details of the contact.
- **Delete** - deletes pictures.
- **Edit** - enables you to move and copy picture and video files between folders.
- **Play Slide Show** - view all pictures in the current folder as a slide show.
- **Folders** - view pictures stored in other folders on your Toshiba phone.
- **Options** - configure the **Pictures & Videos** application.

## Opening a picture

From within the **Pictures & Videos** application, select a picture and select **View**.

## Sending a picture

1. From within the **Pictures & Videos** application, select **Menu** > **Send**.
2. Select the sending method.
3. Enter the destination number and select **Send**.  
Select **Menu** for a list of additional options.

When viewing a picture, select **Menu** to access the following settings:

- **Zoom** - zooms in or out of the selected picture.
- **Play Slide Show** - view all pictures as a slide show.
- **Use as Home screen** - sets the selected picture as wallpaper for the **Home** screen.
- **Beam picture** - sends pictures via Bluetooth.
- **Edit** - edits pictures.
- **Save** - associate a picture with a phone contact or rename the picture.
- **Properties** - displays picture properties, such as file name and size.



# Applications & Multimedia

- **Options** - sets the properties of the **Pictures & Videos** application.

## Accessories

The **Accessories** menu contains the following tools:

- **Calculator**
- **Download Agent**

### Calculator

To access the calculator:

From the **Home** screen, select **Start > More > Accessories > Calculator**.

Use the following keys to operate the calculator:

**Left Navigation** key - 'l'

**Right Navigation** key - 'x'

**Up Navigation** key - '+'

**Down Navigation** key - '-'

**Action** key - '='

### Download Agent

The Download Agent manages the downloaded content on your Toshiba phone.

To access the Download Agent, from the **Home** screen, select **Start > More > Accessories > Download Agent**.

**NOTE:** Select **Menu**, while in the **Download Agent** screen, to view or delete the download status.



You can delete or show the download status from the Menu on the Download Agent screen.

### Internet Sharing

Internet Sharing is a customized tool used for PC or Network connection.

To use Internet Sharing:

1. From the **Home** screen, select **Start > More > Internet Sharing**.
2. Select the PC Connection status.
3. Select the item.



# Applications & Multimedia

## File Explorer

Use the File Explorer tool to view and manage files saved in your Toshiba phone, or on the memory card.

1. From the **Home** screen, select **Start > More > File Explorer**. **My Documents** is displayed.
2. Select the folder in which the files are saved.

## Menu items on the My Documents screen

From the **Home** screen, select **Start > More > File Explorer > Menu**.

The following menu items are displayed in the **My Documents** screen:

- **Send** - sends the selected file via email or MMS.
- **Beam** - sends the file to a contact via Bluetooth.
- **Edit** - allows you to manage the file list by using **Cut, Copy, Paste, Delete, Rename** and **New Folder**.
- **Properties** - displays the information of the selected file.
- **View** - changes the file list viewer type - **Icons** or **List**.
- **Sort By** - changes the file ordering.

- **My Device** - displays the top of the folder tree in your Toshiba phone.
- **Storage Card** - displays the file list in the inserted storage card.
- **My Documents** - displays the files saved in **My Documents**.

## FingerLaunch

The FingerLaunch application helps ensure the security of the data on your Toshiba phone.

To access the FingerLaunch application:

1. From the **Home** screen, select **Start > More > FingerLaunch**. The **Fingerprint Launcher** screen is displayed.
2. Select **Options**.
3. Select the finger to swipe.
4. Swipe the finger three times to enrol.



# Applications & Multimedia

## GoldKey

Your Toshiba phone allows you to lock or unlock your PC remotely, via Bluetooth technology. Using the **GoldKey** application, this security operation is achieved by simply pressing a key on your Toshiba phone, or automatically with the **Auto Lock** option.

There are three types of lock methods:

- **Screen Lock**
- **Screen Saver**
- **Log Off**

## Starting GoldKey

You need to run the GoldKey Registration program on your PC to establish a link between the PC and your Toshiba phone.

When running this service program, you must enter:

- **Lock type**
- **Password**
- **PC name**

This information must then be sent to your Toshiba phone. The link between the PC and your Toshiba phone is finalised when the registration information has been received on your Toshiba phone.

## Java

Your Toshiba phone supports Java applications (known as MIDlets) that are written especially for mobile devices. Java applications include games and utilities.

## Starting the Java application

From the **Home** screen, select **Start > More > Java**. After a brief pause, main screen is displayed. The menu provides the following options:

- **Actions**
- **Install**
- **New Folder**
- **Options**
- **Uninstall All**
- **Certificates**
- **About**
- **Exit**





# Applications & Multimedia

## Installing a Java application

From the **Home** screen, select **Start > More > Java > Menu > Install**.

You must now select where to access the MIDlets from:

- To install from a website select **Browser**. This will launch Internet Explorer Mobile. Navigate to the website where the Java MIDlet is kept. Select the file. It is loaded into the Java application.
- To install from a specific URL, select **URL**. If the URL has already been entered, select it and select **Go**. If the URL has not been entered, select **Add**, and enter the URL description followed by the web address.
- To install from your Toshiba phone, select **Local Files**. All unloaded MIDlets stored in the Mobile Device folder are displayed. Select one from this list to install.

## Selecting the Jad or Jar

The details of the MIDlet you are proposing to install are displayed. Select **Continue** to proceed with the installation.

Once the file has downloaded, you will be asked where you wish to store the download. For ease of

use, you should choose to save the file in **<root>**, the base folder for your Toshiba phone.

## Running a Java MIDlet

Once you have successfully installed the MIDlet, using one of the methods described above, the installed files are displayed on the Java main screen. Scroll down to the desired MIDlet and press the **Action** key to run the Java MIDlet.

## Exiting the Java application

From the main Java screen, select **Menu > Exit**.

## Opera Browser

The Opera Browser tool helps connect your Toshiba phone to the Internet.

## Opening the Opera Browser

1. From the **Home** screen, select **Start > More > More > Opera Browser**.
2. Scroll to view all available links.
3. Select the desired link.

# Applications & Multimedia

## Menu items on the Opera Browser

To access the Opera Browser menu items, from the **Home** screen, select **Start > More > More > Opera Browser > Menu**.

The Opera Browser has the following menu items:

- **Windows** - manages the window.
- **Display** - changes the windows viewer.
- **Tools** - manages bookmarks and displays useful information.
- **Exit** - exits the Opera Browser.

## Picisel Viewer

Picisel Viewer is the tool used to view PDFs and all Microsoft Office (Word, Excel and PowerPoint) files.

### Opening Picisel Viewer

1. From the **Home** screen, select **Start > More > More > Picisel Viewer**.
2. Select the file that you want to view.
3. Press the **Action** key.

## Menu items on the Picisel Viewer screen

From the **Home** screen, select **Start > More > More > Picisel Viewer > Menu**.

The Picisel Viewer has the following menu items:

- **Document View** - opens the selected file.
- **Page** - rotates the window, from Portrait to Landscape or vice versa.
- **Favourites** - shows the viewer file list.
- **History** - shows the viewer usage history.
- **Settings** - allows you to manage preferences, file types, help and file information.
- **Close** - exits Picisel Viewer.

## Pocket MSN

For more information please refer to the **Settings** section.

## SIM Manager

SIM manager enables you to copy your contacts' information from your Toshiba phone to your SIM card or from your SIM card to your Toshiba phone.



# Applications & Multimedia

## Speed Dial

For more information please refer to the **Call functions** section.

## Teleport

The Teleport application enables you to use two functions: Remote Keypad and Remote Screen.

### Remote Keypad

With Remote Keypad you can scroll a PC application, displayed on a PC screen, using your Toshiba phone.

### Remote Screen

With Remote Screen, you can replicate the main display of your Toshiba phone on a PC screen, and operate your Toshiba phone from the PC. Using the PC keyboard and Remote Screen GUI on the PC, actions on the PC are relayed to your Toshiba phone.

## Preparing to use Teleport

- Install the Teleport application to a PC.
- Ensure the Teleport application is activated before installing your Toshiba phone.
- The Teleport application supports the following communication options: USB, Bluetooth, and Wi-Fi.
- Establish a connection between your Toshiba phone and the PC before using the Teleport application.

Select either the Remote Keypad or Remote Screen buttons on the PC.

 **NOTE:** When using Teleport with Wi-Fi, you will need to set Wi-Fi to **Always On** from **Start > Settings > Power Management > Wi-Fi** to avoid the connection timing out.

## To start using Teleport

Perform the following steps on your Toshiba phone:

1. From the **Home** screen, select **Start > More > More > Teleport**.
2. Select either the **Remote Keypad** or **Remote Screen** option.

# Applications & Multimedia

## Teleport Application main screen description

### Remote Keypad

Select the Remote Keypad feature to navigate a PC application using the navigation keys on your Toshiba phone.

Key commands:

**Up Navigation** key - moves the PC cursor up.

**Down Navigation** key - moves the PC cursor down.

**Left Navigation** key - moves the PC cursor to the left.

**Right Navigation** key - moves the PC cursor to the right.

**Action** key - works as the PC Enter key.

**Back** key - hides the Teleport application.

\* key - performs a Page Up on the PC.

# key - performs a Page Down on the PC.

1 through 0 keys - inputs the corresponding digits on the PC.

### Remote Screen

Select the Remote Screen feature to input text data into your Toshiba phone using the PC input device.

### Connection method

Select the Connection Method to connect your Toshiba phone to the PC. These connection methods are: Bluetooth, USB and Wi-Fi.

### Network Port

To set the network port for USB and Wi-Fi, select **Menu > Network Port**.

### COM Ports

To set the COM ports for Bluetooth, select **Menu > COM Ports**.

### PIN Code

To set the Teleport PIN Code, select **Menu > PIN Code**, from within the Teleport application.

### Hide

To set the Teleport visibility, select **Menu > Hide**, from within the Teleport application.

### Help

To view instructions for using Teleport on the phone, select **Menu > Help**.

### About

To view the Teleport version, select **Menu > About**, from within the Teleport application.

### Exit

To quit the Teleport application, select **Menu > Exit**, from within the Teleport application.



# Applications & Multimedia

## TIPtalk

The TIPtalk application enables you to:

- Call an IP phone.
- Use answering machine functions.
- Check the online status of your contacts (Online, Offline, Away, or Busy).
- Notify your contacts of your current online status (Online, Offline, Away, or Busy).
- Send and receive instant messages during a call.



**NOTE:** When using TIPtalk, you will need to set Wi-Fi to **Always On** from **Start > Settings > Power Management > Wi-Fi** to avoid the connection timing out.

## Launching TIPtalk

Select **Start > More > More > TIPtalk**.

A configuration dialog is displayed when you launch TIPtalk for the first time.

## Calling an IP phone

1. From within the TIPtalk application, select **Menu > Show > Contacts**.
2. Select a contact from your contact list.
3. Select **Call**.

## Answering a call automatically

To answer a call automatically, you must check the Automatic answer box on the Configuration screen. This application automatically answers, and redirects the call to the answer message service, ten seconds after the call is received.

## Holding a call

From within the TIPtalk application, select **Menu > Voice Service > Hold** while in a call. To continue the call, select **Menu > Voice Service > Hold**.

## Redialling using outgoing call history

You can store twenty contacts in the outgoing call history contacts at any one time.

To redial using outgoing call history:

1. From within the TIPtalk application, select **Menu > Show > Outgoing Calls**.
2. Select an outgoing call history contact.
3. Select **Call**.

# Applications & Multimedia

## Calling back using incoming call history

You can store twenty contacts in the incoming call history contacts at any one time.

To call back using incoming call history:

1. From within the TIPtalk application, select **Menu > Show > Incoming Calls**.
2. Select an incoming call history contact.
3. Select **Call**.

## Muting the microphone

From within the TIPtalk application, select **Menu > Voice Service > Mute**. To reactivate the microphone select **Menu > Voice Service > Mute** again.

## Switching to handsfree mode

From within the TIPtalk application, select **Menu > Voice Service > Speakerphone**. To deactivate the handsfree mode, simply select **Menu > Voice Service > Speakerphone** again.

## Adding an entry to your contacts list

1. From within the TIPtalk application, select **Menu > Edit Contacts > Add Contact**.

2. Enter the contact name.
3. Select **OK**.

## Deleting an entry from your contacts list

1. From within the TIPtalk application, select **Menu > Show > Contact List**.
2. Select the contact name to remove.
3. Select **Menu > Edit Contacts > Delete Contact**.
4. Select **OK**.

## Playing back a voicemail

1. From within the TIPtalk application, select **Menu > Show > Incoming Calls**.
2. Select an incoming call history entry, marked with a voicemail icon.
3. Select **Menu > Voice Service > Play Back**.

## Instant messaging (IM)

You can send and receive instant messages using the TIPtalk application.

To start instant messaging:

1. Call another TIPtalk user.



# Applications & Multimedia

2. Select **Menu > Send Instant Message** once the call has been connected.
3. Enter your message in the second text box.
4. Select **Send** to send your message. All the messages in the thread are displayed in the first message box.

## Changing your current status

From within the TIPtalk application, select **Menu > My Status** and select your current status (offline, online, busy or away).

## Configuring TIPtalk

1. From within the TIPtalk application, select **Menu > Configuration**.
2. Enter your user name, password, server IP, and server port. In addition, if two or more network adapters are shown, designate a network adapter to use.



**NOTE:** If you select the **Automatic answer** box, TIPtalk will automatically answer a call. The caller can then leave a voice message.

## Zoom

The Zoom application enables you to magnify or decrease the current window size. you can magnify the window to eight times the standard size. You can use the Set Zoom Level box to set a specific zoom level in the Viewer or in Edit Mode. The Zoom application is launched at a default level of x2 (200%). It can be set to the following levels:

- x2 (200%)
- x4 (400%)
- x8 (800%)

To launch the Zoom application, press and hold the **Up Side** key.

Use the following keys when using the Zoom application:

- Press the **End** key to close the zooming application and return to the **Home** screen.
- Press the **Left Softkey** to zoom-in.
- Press the **Right Softkey** to zoom-out.
- Press the **Up Navigation** key to scroll up the zoomed screen.
- Press the **Down Navigation** key to scroll down the zoomed screen.

# Applications & Multimedia

- Press the **Right Navigation** key to scroll right in the zoomed screen.
- Press the **Left Navigation** key to scroll left in the zoomed screen.





# Other applications

## Battery information

Battery performance depends on many factors, such as your Service Provider's network configuration, signal strength, the temperature of the environment in which you operate your Toshiba phone, the features and/or settings you select and use, items attached to your phone's connecting ports, and your voice, data, and other program usage patterns.

### Checking the battery power

From the **Home** screen, select **Start > Settings > Power Management**.

### Optimizing the power performance

From the **Home** screen, select **Start > Settings > Power Management**, and adjust the backlight, display, and Wi-Fi settings.

## Managing a low battery

When the low battery warning is displayed, do the following:

1. Save your current data.
2. Charge the battery as soon as possible.
3. Turn your Toshiba phone off.

For information about charging the battery, refer to the **Getting Started** section.



**WARNING:** There is a danger of explosion if the battery is incorrectly replaced. To reduce risk of fire or burns, do not disassemble, crush, puncture, short external contacts, expose to temperature above 60°C (140°F), or dispose of battery in fire or water. Replace only with specified batteries according to the local regulations.



**NOTE:** It is recommended that you save your memory data to a PC or storage card. The manufacturer is not responsible for data lost or altered due to battery discharge.



# Other applications

## PC requirements to run ActiveSync 4.2

The requirements for this section were published from Microsoft's website for ActiveSync 4.2: <http://www.microsoft.com/windowsmobile/downloads/as-sysreq42.msp>

## Supported operating systems for ActiveSync 4.2

- Windows 2000 Service Pack 4.
- Windows Server 2003 Service Pack 1.
- Windows Server 2003 Service Pack 1 for Itanium-based Systems.
- Windows Server 2003, Standard x64 Edition.
- Windows XP Media Center Edition.
- Windows XP Professional x64 Edition.
- Windows XP Service Pack 1.
- Windows XP Service Pack 2.
- Windows XP Tablet PC Edition.

## Requirements

- Microsoft Outlook 2000, Microsoft Outlook XP, or Microsoft Outlook 2003 messaging and collaboration clients required for synchronization to the desktop or portable computer of e-mail, Calendar, Contacts, Tasks, and Notes (Outlook 2003 is recommended).
- Microsoft Office 2000, Microsoft Office XP or Microsoft Office 2003.
- Microsoft Internet Explorer 6.0 or later (required).
- Microsoft Systems Management Server 2.0.

## Mobile device operating systems supported by ActiveSync 4.2

- Microsoft Windows Mobile 5.0.
- Messaging and Security Feature Pack for Microsoft Windows Mobile 5.0.
- Microsoft Windows Mobile 2003 Second Edition.
- Microsoft Windows Mobile 2003.
- Microsoft Pocket PC 2002, Microsoft Windows CE OS version 3.0.
- Microsoft Smartphone 2002, Microsoft Windows CE OS version 3.0.



# Specifications

## System Information

Processor

Marvell® PXA270 Processor at 416 MHz

Memory

RAM : 64 MB

ROM : 128 MB

Operating System

Windows Mobile® 5.0 for Smartphone

## UMTS/HSDPA GSM/GPRS/EDGE

### Frequency Range

Within 3G (UMTS) 2100

1920 - 2170 MHz

Within GSM 900

880 - 960 MHz

Within DCS 1800

1710 - 1880 MHz

Within PCS 1900

1850 - 1990 MHz

### Continuous Talk Time

Within 3G (UMTS) area

Approx. 140 mins

Video Call

Approx. 75 mins

Within GSM area

Approx. 280 mins

### Continuous Standby Time

Within 3G (UMTS) area

Approx. 290 hrs

Within GSM area

Approx. 250 hrs

### Charging Time

Approx. 150 mins

### Dimensions (H x W x D)

Approx. 96mm x 49mm x 23mm



# Specifications

## Maximum Output

Within 3G (UMTS) 2100	Class 3	0.25 W
Within GSM 900	Class 4	2 W
Within DCS 1800	Class 1	1 W
Within PCS 1900	Class 1	1 W

## Weight

Approx. 135 g

## AC Adapter

Input Voltage	100 to 240 VAC	50/60 Hz
Charging Temperature Range	5 to 35 °C	

## Display

LCD	2.3" TFT LCD
Resolution	240 x 320 (64k colours)

## Audio/Video Codec

Audio	AMRNB, AAC, AAC+, eAAC+, MP3, WMA
Video	H263, MPEG4, WMV



# Specifications

## Connection

Bluetooth

Bluetooth™ ver 2.0 + EDR (Power Class 2)

GAP (Generic Access Profile)

SPP (Serial Port Profile)

HSP (Headset Profile)

HFP (Hands Free Profile)

PAN (Personal Area Networking)

AVRCP (Audio/Video Remote Control Profile)

A2DP (Advanced Audio Distribution Profile)

Wireless LAN

IEEE 802.11b/g

WPA, WPA2, WEP, TKIP, AES

## Interface

Cable and Phone Charging

mini USB (Client, Full Speed) / Charger

Headset Connector

2.5 mm Stereo headset

Expansion Slot

miniSD



# Troubleshooting



<b>Problem</b>	<b>Possible Causes and Solutions</b>
Cannot turn the power on	<ul style="list-style-type: none"><li>• Ensure that the battery is inserted correctly (pg 26).</li><li>• Ensure that the battery is charged (pg 28).</li></ul>
Cannot charge the battery	<ul style="list-style-type: none"><li>• Ensure that the battery is inserted correctly.</li><li>• Ensure that the AC adapter and battery pack connectors are clean.</li></ul>
Cannot make or receive voice and video calls	<ul style="list-style-type: none"><li>• Check the signal strength indicator. If the display indicates a poor signal adjust your physical location to be clear of obstructions that may block the signal.</li><li>• A video call can only be made or received in an area with 3G coverage. Ensure that the sign for indicating you are in an area with 3G coverage appears on the display in standby mode.</li><li>• If you enter the PIN code incorrectly three times in a row, the PIN lock will be set, preventing calls being made because access to the SIM card is blocked (pg 60). Enter the PUK code to cancel the PIN lock.</li><li>• If the indicator appears on the display, enter your security code to cancel the phone lock.</li></ul>
Cannot use the Web	<ul style="list-style-type: none"><li>• Check your subscription status. Contact your service provider.</li><li>• The network settings may be incorrect. Check the network settings. For details on network settings, contact your service provider.</li></ul>
Cannot use SMS and MMS	<ul style="list-style-type: none"><li>• Check your subscription status. Contact your service provider.</li><li>• Ensure that the service centre number is correct. For details on the service centre number, contact your service provider.</li></ul>

# Health and safety

## General

- Always use your Toshiba phone in the intended manner. Incorrect usage may affect performance. Only qualified service personnel should install or repair the phone and its accessories.
- To avoid permanent damage to your Toshiba phone, use only Toshiba approved batteries and accessories.
- The bundled battery and AC adapter is only for use with your Toshiba phone. Do not use this battery or AC adapter with any other device as this may cause permanent damage to the device, battery and AC adapter.
- Before connecting your Toshiba phone to another device, read the supporting documentation to confirm that the other device is compatible.
- When making emergency calls from your Toshiba phone, ensure that the phone is switched on and in service.
- Interference may affect the performance of your Toshiba phone. If the display indicates a poor signal adjust your physical location to be clear of obstructions that may block the signal.
- When your Toshiba phone is used for extended periods of time, especially in high temperature conditions, the phone surface could become hot. Please use caution when touching the phone under such conditions.
- When using ear buds or other headphones, be careful not to listen at excessive volumes. Listening to very loud sound levels may lead to hearing loss. Also, listening through the ear buds or headphones for prolonged periods of time, even at normal sound levels, may lead to hearing loss. You should consult your doctor for more information on proper use of ear buds or headphones.
- It is recommended that pregnant and young women take precautions while in a call and keep the phone at a distance from their lower abdomen. For this situation, use of a hands free kit is recommended.





# Health and safety

## Operating environment

- Do not handle your Toshiba phone while driving or when operating machinery. If you must handle the phone while driving, park the vehicle before conversing. If using an integrated hands free device, make sure the phone is securely placed in its holder.
- Switch your Toshiba phone off if you are entering a hospital or health care facilities. Medical equipment may be affected by phone usage. Always follow building regulations governing phone usage.
- Switch your Toshiba phone off when travelling on an aircraft. The phone signal may interfere with the systems in the aircraft. You are legally bound to comply with this recommendation.
- Switch your Toshiba phone off in any facility where posted notices prohibit phone usage.
- Do not use your Toshiba phone when refuelling. You should keep the phone away from fuel and chemicals.
- Switch your Toshiba phone off when blasting is in progress and observe all provided guidelines and regulations.
- Switch your Toshiba phone off in areas with potentially explosive atmospheres. For example, fuel storage areas and spray paint facilities.
- Switch your Toshiba phone off when outdoors during an electrical storm.
- Only qualified personnel should install the device in a vehicle. Faulty installation or service may be dangerous and may invalidate any warranty. For more information, consult your vehicle manufacturer or representative.



# Health and safety

## Electronic devices

- If you wear a pacemaker, or are in the company of someone who does, you should be aware that there is a small risk of mobile phone usage interfering with the operation of the pacemaker. You should contact your doctor, or the manufacturer of the pacemaker, for more information.
- Mobile phone usage may interfere with some hearing aids. If this happens you should contact your service provider or doctor.
- Mobile phone usage may interfere with the functionality of inadequately shielded medical devices. Consult a physician or the manufacturer of the device to ensure safe procedures are used.
- Mobile phone usage may interfere with the functionality of any inadequately shielded electronic system in a motor vehicle. Examples include airbags and fuel injection. You should contact the manufacturer of the vehicle to ensure that the electronic system is properly shielded.

## Battery safety

Your Toshiba phone is powered by a rechargeable battery. The full performance of a new battery is achieved only after two or three complete charge and discharge cycles. The battery can be charged and discharged hundreds of times but it will eventually wear out. When the talk and standby times are noticeably shorter than normal, it is recommended that you buy a new battery.

- A new battery, or one that has not been used for a long time, could have reduced capacity during initial use.
- The battery can only be charged in temperatures between +5 °C (+41 °F) and +35°C (+95 °F).
- Only use batteries approved by Toshiba and only recharge the battery with the recommended charger supplied by Toshiba.
- When the charger is not in use, disconnect it from the power source.
- Do not leave the battery connected to the charger and power source for longer than necessary as overcharging will shorten the lifespan of the battery.



# Health and safety

- Do not short-circuit the battery. Accidental short-circuiting can occur when a metallic object causes a direct connection between the + and - terminals of the battery.
- Do not leave the battery in areas of extreme cold or heat as this will affect the performance of the battery. Areas of extreme cold include a refrigerator, and areas of extreme heat include a car exposed to direct sunlight.
- Do not dispose of the battery in a fire.
- Do not dispose of the battery in an ordinary bin. The battery contains toxic chemicals and must be disposed appropriately. Contact your local authorities for more information.

## AC adapter and cable safety

- Do not use a damaged or worn AC adapter or cable. The use of a damaged or worn AC adapter or cable could result in electric shock, burns or fire. Contact an authorised Toshiba service provider immediately to obtain suitable replacements.
- Do not bend or twist the AC cable.
- Do not pull on the AC cable in order to remove the plug from a socket.
- Do grasp the plug directly when unplugging the AC cable to avoid causing any damage to the cable.
- Do not place heavy objects on the AC adapter or cable.



# Health and safety

## Emergency calls

Calls cannot be made to emergency services while data communication is being performed within a GSM area. If the system mode is set to UMTS Only or GSM Only, calls cannot be made to emergency services if the selected network is unavailable. Also, calls may not be able to be made to emergency services depending on the network services of some service providers.



**IMPORTANT:** You can still make calls to emergency services when the SIM card is not inserted, the SIM card is locked, the phone lock is set, Fixed Dialling Numbers is set, Flight Mode is set or Call Barring Service is set.

There is no guarantee that a connection can be established in all countries and areas because operation of your phone differs depending on the wireless network, wireless signal and your setting status. Do not rely solely on your mobile phone when you need to make emergency calls.

## FCC RF exposure information

Your Toshiba phone is a radio transmitter and receiver. It is designed and manufactured not to exceed the emission limits for exposure to radio frequency (RF) energy set by the Federal Communications Commission of the U.S. Government.

The guidelines are based on standards that were developed by independent scientific organisations through periodic and thorough evaluation of scientific studies. The standards include a substantial safety margin designed to assure the safety of all persons, regardless of age and health.

The exposure standard for wireless handsets employs a unit of measurement known as the Specific Absorption Rate, or SAR. The SAR limit set by the FCC is 1.6W/kg. The tests are performed in positions and locations (e.g., at the ear and worn on the body) as required by the FCC for each model. The SAR value for this model handset when tested for use at the ear is 0.218W/kg and when worn on the body, as described in this user guide, is 1.439W/kg.



# Health and safety

## Body-worn operation

This phone was tested for typical body-worn operations with the back of the phone kept at a distance of 1.5cm from the body. To maintain compliance with FCC RF exposure requirements, use accessories that maintain a 1.5cm separation distance between your body and the back of the phone. The use of belt clips, holsters and similar accessories should not contain metallic components. The use of accessories that do not satisfy these requirements may not comply with FCC RF exposure requirements, and should be avoided.

The FCC has granted an Equipment Authorization for this model handset with all reported SAR levels evaluated as in compliance with the FCC RF emission guidelines. SAR information on this model handset is on file with the FCC and can be found under the Display Grant section of <http://www.fcc.gov/oet/fccid> after searching on FCC ID SP2-RG4-E01.

Additional information on Specific Absorption Rates (SAR) can be found on the Cellular Telecommunications & Internet Association (CTIA) website at <http://www.phonefacts.net>.

## European RF Exposure Information

Your Toshiba phone is a radio transmitter and receiver. It is designed not to exceed the limits for exposure to radio waves recommended by international guidelines. These guidelines were developed by the independent scientific organisation ICNIRP and include safety margins designed to assure the protection of all persons, regardless of age and health.

The guidelines use a unit of measurement known as the Specific Absorption Rate, or SAR. The SAR limit for mobile devices is 2 W/kg and the SAR value for this device when tested at the ear was 0.405W/kg\*. As mobile devices offer a range of functions, they can be used in other positions, such as on the body as described in this user's guide\*\*. In this case, the tested SAR value is 0.838W/kg.

As SAR is measured utilising the device's highest transmitting power, the actual SAR of this device while operating is typically below that indicated above. This is due to automatic changes to the power level of the device to ensure it only uses the minimum level required to reach the network.



## Health and safety

The World Health Organization has stated that present scientific information does not indicate the need for any special precautions for the use of mobile devices. They state that if you want to reduce your exposure then you can do so by limiting the length of calls or using a 'hands-free' device to keep the mobile phone away from the head and body. Additional Information can be found on the website of the World Health Organization (<http://www.who.int/emf>).

\* The tests are carried out in accordance with international guidelines for testing.

\*\* Please see the <FCC RF Exposure Information> section about body worn operations.

The following Information is only for EU-Member States:



The use of the above symbol indicates that this product may not be treated as household waste. By ensuring this product is disposed of correctly, you will help prevent potential negative consequences for the environment and human health, which could otherwise be caused by inappropriate waste handling of this product. For more detailed information about recycling of this product, please contact your local city office, your household waste disposal service or the shop where you purchased the product.

# Health and safety

## Purchase record

For your future reference, we recommend that you fill in your purchase details in the form below.

Serial Number\*:

Dealer Name:

Purchase Date:

\* The serial number is printed on the bottom of the battery compartment.



# Menu Tree

## Start

Internet Explorer

Tasks

Windows Media

Calendar

Messaging

1 Text Message

2 Outlook Email

3 MMS

4 New Account

Contacts

ActiveSync

Call History

Settings

1 Phone

2 Sounds

3 Profiles

4 Home Screen

5 Clock & Alarm

6 Connections

7 Security

8 Remove Programs

9 Power Management

0 More...

1 Accessibility

2 Regional Settings

3 Owner Information

4 Error Reporting

5 Video Call

6 SIMLock

7 Format User Partition

8 About

Games

Voice Notes

Pictures & Videos

Accessories

Calculator

Download Agent

Internet Sharing

File Explorer

FingerLaunch

GoldKey

Java

Opera Browser

Picxel Viewer

Pocket MSN

SIM Manager

Speed Dial

Teleport

TIPTalk

(SIM Tool Kit)



# Index

## Numerics

3G coverage 109

## A

AC adapter 18, 113

AC cable 18, 113

Accessibility 58

ActiveSync 29, 45, 105

Alarm 58

Attachment 47

## B

Battery 26, 28, 104

Battery life 59

Battery pack 18, 109

Battery power 28, 104

Battery safety 112

Beam 73

Bluetooth 11, 70

Bluetooth connection 29, 72

## C

Calculator 93

Calendar 84

Call Barring 62

Call History 33, 38

Caller ID 63

Camera 89

Clock 58

Conference 35

Contacts 32, 36, 86

Copy files 83

Create an email message 45

## D

Date 58

Delete a message 41

Device lock 59

Display indicators 22

Download Agent 93





# Index

## E

Earpiece 19  
Email 40, 42  
Emergency calls 32, 114  
Exchange server 29, 30, 42, 45

## F

FCC notice 16  
File Explorer 94  
Fingerprint 61  
Flight mode 75  
Forward a message 41

## G

Games 89, 95

## H

Hard Reset 15  
Home screen 21, 56  
Hotmail 40, 52

## I

Information to user 17  
Internet email account 42  
Internet Explorer Mobile 77

## J

Java 95

## K

Keypad 19  
Keypad lock 59

## L

Language 59

## M

Main display 19  
Make a call 32  
MMS messages 40, 48  
Modem 29  
Multimedia message 40, 48  
Multi-press Mode 54

# Index

## O

- Opera Browser 96
- Operating environment 111
- Owner information 58

## P

- Phone charging connector 19
- Picxel Viewer 97
- Pictures 89
- Pocket MSN 52

## R

- Receiving a call 34
- Removing Programs 64
- Reply to a message 41, 46

## S

- SIM card 25
- SIM Manager 97
- SIM PIN 59
- SIM PIN enable 59
- SMS 40
- Softkey 19

- Speakerphone 36
- Speed dial 33
- Start and stop synchronization 31
- Synchronizing 29
- Synchronizing Media 31

## T

- Tasks 78
- Text message 40
- Time 58

## U

- USB cable 18

## V

- Video call 37
- Videos 89
- Voice Notes 89
- VPN connection 68

## W

- Windows Media 80



# Index

## **x**

XT9 Mode 55

## **z**

Zoom 102

